

Government Gazette

of the State of

New South Wales

Number 138

Friday, 22 December 2017

The New South Wales Government Gazette is the permanent public record of official notices issued by the New South Wales Government. It also contains local council and other notices and private advertisements.

The Gazette is compiled by the Parliamentary Counsel's Office and published on the NSW legislation website (www.legislation.nsw.gov.au) under the authority of the NSW Government. The website contains a permanent archive of past Gazettes.

To submit a notice for gazettal – see Gazette Information.

GOVERNMENT NOTICES

Miscellaneous Instruments

AIR TRANSPORT (DEREGULATED ROUTES) ORDER (NO 2) 2017

I, Andrew Constance, the Minister for Transport and Infrastructure, in pursuance of section 4A (1) of the *Air Transport Act 1964*, make the following Order.

Dated, this 18th day of December 2017.

THE HON ANDREW CONSTANCE MP
Minister for Transport and Infrastructure

Explanatory note

Under section 4A (1) of the *Air Transport Act 1964* (the Act), the Minister for Transport and Infrastructure may, by order published in the Gazette, declare specified routes to be deregulated routes for the purposes of the Act. Certain routes were declared to be deregulated routes by an Order made under section 4A (1) of the Act and published in the Gazette on 3 March 2017.

The object of this Order is to declare a further route to be deregulated route, namely the routes linking Sydney (Kingsford-Smith) Airport with Taree. As a consequence, the declaration in the Order published in the Gazette on 3 March 2017 is repealed and re-made in this Order.

1 Name of Order

This Order is the *Air Transport (Deregulated Routes) Order (No 2) 2017*.

2 Commencement

This Order commences on date of publication in the NSW Government Gazette and continues in force until revoked.

3 Definitions

In this Order:

the Act means the *Air Transport Act 1964*.

4 Declaration of deregulated routes

In pursuance of section 4A (1) of the Act, the following routes are declared to be deregulated routes for the purposes of the Act:

- (a) the routes between Sydney (Kingsford-Smith) Airport and each of the following localities, namely, Albury, Armidale, Ballina, , Cobar, Coffs Harbour, Cooma, Dubbo, , Griffith, Lismore, Merimbula, , Moruya, Mudgee, Narrabri, , Orange, , Port Macquarie, Tamworth, Taree, Wagga Wagga and Williamtown, and
- (b) any routes that do not begin or end at, or pass through, Sydney (Kingsford-Smith) Airport.

5 Repeal

The Order made in pursuance of section 4A (1) of the Act and published in the Gazette on 3 March 2017 is repealed.

Roads and Maritime Notices

MARINE SAFETY ACT 1998

MARINE NOTICE

Section 12(2)

REGULATION OF VESSELS – EXCLUSION ZONE

Location

Lake Albert, Wagga Wagga

Duration

8:00am to 1:00am – Sunday 31 December 2017 to Monday 1 January 2018.

Detail

An aquatic festival involving passive and powered vessels and a fireworks display will be conducted on the navigable waters of Lake Albert.

The aquatic festival will involve the use of high speed power vessels, including persons being towed at speed using tow-lines and the possibility of persons in the water from time to time, presenting a potential hazard to other waterway users.

The fireworks display will be staged from a barge at the above location. The area directly around this firing position may be dangerous and hazardous while the fireworks are being launched.

An **EXCLUSION ZONE** is specified during the event at the above location and will comprise the entirety of Lake Albert. This will in effect close the Lake between the above times for this event. The zone will be indicated by the presence of control vessels.

Unauthorised vessels and persons are strictly prohibited from entering the exclusion zone (the Lake).

Vessel operators and persons in the vicinity must keep a proper lookout, exercise caution and keep well clear of the fireworks and aquatic festival and support vessels.

Penalties may apply (section 12(5) – *Marine Safety Act 1998*)

For full details visit the Roads and Maritime Services website – www.rms.nsw.gov.au/maritime

Marine Notice: SO1780

Date: 18 December 2017

Deon Voyer
Manager Operations South
Delegate

MARINE SAFETY ACT 1998

MARINE NOTICE

Section 12 (2)

REGULATION OF VESSELS – EXCLUSION ZONE

Location

Tweed River, Tweed Heads – Jack Evans Boat Harbour

Duration

8:00pm to 1:00am – Sunday 31 December 2017 to Monday 1 January 2018

Detail

A fireworks display will be conducted over navigable waters of Tweed River. Fireworks will be launched from a firing barge at the above location. The area directly around this firing position may be dangerous and hazardous while fireworks are being launched.

An **EXCLUSION ZONE** is specified during the event, extending for a radius of 75 metres around the firing barge. The area will be marked by lit buoys and patrolled by control vessels.

Vessel operators and persons in the vicinity must keep a proper lookout, exercise caution and keep well clear of the fireworks barge and support vessels.

Unauthorised vessels and persons are strictly prohibited from entering the exclusion zone.

Penalties may apply (section 12 (5) – *Marine Safety Act 1998*)

For full details visit the Roads and Maritime Services website – www.rms.nsw.gov.au/maritime

Marine Notice NH17125

Date: 18 December 2017

Darren Hulm
A/Manager Operations North
Delegate

MARINE SAFETY ACT 1998

MARINE NOTICE

Section 12(2)

REGULATION OF VESSELS – EXCLUSION ZONE

Location

Hunter River, Stockton – between Stockton Ferry Wharf and Punt Road

Duration

8.55pm to 9.20pm – Sunday 31 December 2017

Detail

A fireworks display will be conducted over navigable waters of the Hunter River. Fireworks will be launched from a firing barge at the above location. The area directly around this firing position may be dangerous and hazardous while fireworks are being launched.

An **EXCLUSION ZONE** is specified during the event, extending for a radius of 140 metres around the firing barge. This area will be indicated by the presence of control vessels which will be stationed on the boundary.

Unauthorised vessels and persons are strictly prohibited from entering the exclusion zone.

Vessel operators and persons in the vicinity must keep a proper lookout, exercise caution and keep well clear of the fireworks barge and support vessels.

Penalties may apply (Section 12(5) – *Marine Safety Act 1998*)

For full details visit the Roads and Maritime Services website – www.rms.nsw.gov.au/maritime

Marine Notice NH17132

Date: 18 December 2017

Mike Baldwin
Manager Boating Operations Hunter
Delegate

MARINE SAFETY ACT 1998

MARINE NOTICE

Section 12(2)

REGULATION OF VESSELS – EXCLUSION ZONE

Location

Camden Haven Inlet, Laurieton – adjacent to the Laurieton United Services Club

Duration

8.00pm to 10.00pm – Sunday 31 December 2017

Detail

A fireworks display will be conducted over navigable waters of Camden Haven Inlet. Fireworks will be launched from a firing barge at the above location. The area directly around this firing position may be dangerous and hazardous while fireworks are being launched.

An **EXCLUSION ZONE** is specified during the event which will be indicated by the presence of a control vessel stationed on the boundary.

Unauthorised vessels and persons are strictly prohibited from entering the exclusion zone.

Vessel operators and persons in the vicinity must keep a proper lookout, exercise caution and keep well clear of the fireworks display and support vessel.

Penalties may apply (section 12(5) – *Marine Safety Act 1998*)

For full details visit the Roads and Maritime Services website – www.rms.nsw.gov.au/maritime

Marine Notice: NH17134

Date: 18 December 2017

Darren Hulm
A/Manager Operations North
Delegate

MARINE SAFETY ACT 1998

MARINE NOTICE

Section 12(2)

REGULATION OF VESSELS – EXCLUSION ZONE

Location

Hastings River, Port Macquarie – between Town Wharf and East of Pelican Island.

Duration

8.30pm to 9.30pm – Sunday 31 December 2017; and

10.30pm to 12:30am – Sunday 31 December to Monday 1 January 2018

Detail

A fireworks display will be conducted over navigable waters of the Hastings River. Fireworks will be launched from a firing barge. The area directly around this firing position may be dangerous and hazardous while fireworks are being launched.

An **EXCLUSION ZONE** is specified during the event which will be indicated by the presence of control vessels stationed on the boundary.

Unauthorised vessels and persons are strictly prohibited from entering the exclusion zone.

Vessel operators and persons in the vicinity must keep a proper lookout, exercise caution and keep well clear of the fireworks display and support vessels.

Penalties may apply (section 12(5) – *Marine Safety Act 1998*)

For full details visit the Roads and Maritime Services website – www.rms.nsw.gov.au/maritime

Marine Notice: NH17133

Date: 19 December 2017

Darren Hulm
A/Manager Operations North
Delegate

MARINE SAFETY ACT 1998

MARINE NOTICE

Section 12(2)

REGULATION OF VESSELS – EXCLUSION ZONE

Location

Clarence River, Yamba – adjacent Main Beach and Whiting Beach

Duration

9.30am to 12.30pm – Sunday 7 January 2018

Detail

A swim event will be conducted on the waters of Clarence River at the location specified above.

An **EXCLUSION ZONE** is specified during the event, which will be marked by buoys and the presence of control vessels.

Unauthorised vessels and persons are prohibited from entering the exclusion zone.

All vessel operators and persons in the vicinity of the event should keep a proper lookout, keep well clear of competitors and support vessels, and exercise extreme caution.

Penalties may apply (section 12(5) – *Marine Safety Act 1998*)

For full details visit the Roads and Maritime Services website – www.rms.nsw.gov.au/maritime

Marine Notice: NH1801

Date: 19 December 2017

Darren Hulm

A/Manager Operations North

Delegate

MARINE SAFETY ACT 1998

Section 12(2)

MARINE NOTICE

REGULATION OF VESSELS – EXCLUSION ZONE

Location

Manning River, Taree – adjacent to Queen Elizabeth Park, Taree – between Goat Island and Taree Regional Boat ramp.

Duration

7.00am to 5.30pm on the following dates:

- Friday 12 January 2018
- Saturday 13 January 2018
- Sunday 14 January 2018

Detail

A rowing regatta will be conducted on navigable waters of the Manning River as above.

An **EXCLUSION ZONE** is specified during the event, which will be monitored and patrolled by control vessels at the above location.

Provision has been made for vessels to transit the exclusion zone during breaks in the racing. Control vessels will, at times during the event, authorise local vessel traffic to transit the exclusion zone.

All vessel operators and persons in the vicinity of the event must comply with directions issued from control vessels, keep a proper lookout, keep well clear of competing and support vessels and exercise caution.

Unauthorised vessels and persons are prohibited from entering the exclusion zone during the times above.

Penalties may apply (Section 12(5) – *Marine Safety Act 1998*)

For full details visit the Roads and Maritime Services website – www.rms.nsw.gov.au/maritime

Marine Notice NH17116

Date: 19 December 2017

Darren Hulm
A/Manager Operations North
Delegate

MARINE SAFETY ACT 1998

MARINE NOTICE

Section 12(2)

REGULATION OF VESSELS – EXCLUSION ZONE

Location

Coffs Harbour – The Jetty

Duration

8.30pm to 10.00pm – Sunday 31 December 2017

Detail

A fireworks display will be conducted over navigable waters of Coffs Harbour. Fireworks will be launched from a firing barge at the above location. The area directly around this firing position may be dangerous and hazardous while fireworks are being launched.

An **EXCLUSION ZONE** is specified during the event which will be indicated by the presence of control vessels stationed on the boundary.

Unauthorised vessels and persons are strictly prohibited from entering the exclusion zone.

Vessel operators and persons in the vicinity must keep a proper lookout, exercise caution and keep well clear of the fireworks display and support vessels.

Penalties may apply (section 12(5) – *Marine Safety Act 1998*)

For full details visit the Roads and Maritime Services website – www.rms.nsw.gov.au/maritime

Marine Notice: NH17135

Date: 19 December 2017

Darren Hulm
A/Manager Operations North
Delegate

ROADS ACT 1993

LAND ACQUISITION (JUST TERMS COMPENSATION) ACT 1991

Notice of Compulsory Acquisition of Land at Barraganyatti in the Kempsey Shire Council Area

Roads and Maritime Services by its delegate declares, with the approval of His Excellency the Governor, that the land described in the schedule below is acquired by compulsory process under the provisions of the *Land Acquisition (Just Terms Compensation) Act 1991* for the purposes of the *Roads Act 1993*.

K DURIE

Manager, Compulsory Acquisition & Road Dedication
Roads and Maritime Services

Schedule

All those pieces or parcels of land situated in the Kempsey Shire Council area, Parish of Barraganyatti and County of Dudley, shown as:

Lots 13, 15 and 17 Deposited Plan 1174518, being part of the land in Certificate of Title Auto Consol 14256-122;

Lots 82 and 85 Deposited Plan 1175557, being part of the land in Certificate of Title 48/752403; and

Lot 8 Deposited Plan 1177020, Lot 56 Deposited Plan 1172326, Lots 83 and 84 Deposited Plan 1175557, Lot 18 Deposited Plan 1174518 and Lot 100 Deposited Plan 1197519 being parts of the land dedicated as Tamban State Forest No 526, by proclamation in Government Gazette No 111 of 27 July 1917 folio 3878.

The land is said to be in the possession of Forestry Corporation of NSW.

(RMS Papers: SF2017/129621; RO SF2013/044727)

ROADS ACT 1993

Notice of Dedication of Land as Public Road at Erina Heights and Wamberal in the Central Coast Council Area Roads and Maritime Services, by its delegate, dedicates the land described in the schedule below as public road under section 10 of the *Roads Act 1993*.

K DURIE

Manager, Compulsory Acquisition & Road Dedication
Roads and Maritime Services

Schedule

All those pieces or parcels of land situated in the Central Coast Council area, Parish of Kincumber and County of Northumberland, shown as:

Lots 3, 4 and 5 Deposited Plan 1217371;

Lot 18 Deposited Plan 599180;

Lot 11 Deposited Plan 1148632;

Lots 17 to 22 inclusive Deposited Plan 1149729;

Lots 31 and 32 Deposited Plan 1155945;

Lots 15 to 20 inclusive Deposited Plan 1150330;

Lots 71 and 72 Deposited Plan 1210387;

Lots 67, 68, 69, 71, 72 and 73 Deposited Plan 1150765;

Lots 86 to 102 inclusive Deposited Plan 1215036;

Lot 1 Deposited Plan 818879;

Lots 100 and 101 Deposited Plan 1002385;

Lots 28 and 29 Deposited Plan 218413;

Lot 18 Deposited Plan 654360;

Lot 17 Deposited Plan 654359; and

Lot 1 Deposited Plan 579338.

(RMS Papers: SF2014/080501; RO SF2013/080145)

ROAD TRANSPORT (GENERAL) REGULATION 2013

Rowing Boat Trailer Combination Exemption Notice 2017

I, Roger Weeks, Director Compliance, Roads and Maritime Services, pursuant to Clause 50M of the Road Transport (General) Regulation 2013, exempt motor vehicle and trailer combinations to which this Notice applies from the requirements of Clauses 50L(1)(a)(iii) and 50L(1)(f) of Part 3A to the Road Transport (General) Regulation 2013 on the basis of the provisions in the Schedule of this Notice.

ROGER WEEKS
Director Compliance
Roads and Maritime Services
15 December 2017

SCHEDULE

PART 1 – PRELIMINARY

1.1 Citation

This Notice may be cited as the ***Rowing Boat Trailer Combination Exemption Notice 2017***.

1.2 Commencement

This Notice takes effect on and from the date of publication in the *New South Wales Government Gazette*.

1.3 Effect

This Notice remains in force up to and including 31 October 2022 unless it is amended or repealed earlier.

1.4 Interpretation

- 1.4.1 Unless stated otherwise in this Notice, the words and expressions used in this Notice have the same meaning as those defined in the *Road Transport Act 2013* and the statutory rules.
- 1.4.2 Except where a contrary intention is indicated, the notes in the text of this Notice do not form part of this Notice.

1.5 Revocation

This Notice revokes and replaces the Rowing Boat Trailer Combination Exemption Notice 2017, dated 17 November 2017 published in the Government Gazette No 126 of 24 November 2017.

PART 2 – APPLICATION

2.1 Application

- 2.1.1 This Notice applies to a motor vehicle and trailer combination:
- (i) which comprises:
 - (a) a motor vehicle; and
 - (b) a trailer designed to carry a load that is a rowing boat commonly known as a dragon boat, outrigger canoe, kayak, surf ski, rowing shell or a similar rowing; and
 - (ii) where the motor vehicle does not exceed 4.5 tonnes Gross Vehicle Mass, and
 - (iii) where the trailer does not exceed 4.5 tonnes Gross Vehicle Mass, and
 - (iv) where the trailer load comprises a vessel as described in 2.1.1(i)(b).
- 2.1.2 Where the trailer's rear overhang (ROH) together with the rear projection (RP) of its load extends more than 3.7 metres from the trailer's rear overhang line, the combination must operate similar to a heavy vehicle combination, and in accordance with:
- (i) the general operating conditions made under Part 2, Division 1 of Schedule 1 to the **Multi-state Class 1 Load Carrying Vehicles Dimension Exemption Notice 2016 (No. 1)** provided on the RMS webpage at [NSW Oversize Load Carrying Vehicles](#); and
 - (ii) the route & travel restrictions made under Appendix 2 to the **Class 1 Load Carrying Vehicles Notice 2014** provided on the NHVR website at [NSW State Transitional notices](#).
- 2.1.3 Failure to comply with the Notices at 2.1.2 (i) or (ii) when required to do so renders the driver or registered operator of the combination liable to an offence against clause 50C of the Road Transport (General) Regulation 2013.

NOTE: a vehicle combination operating under this Notice is considered an eligible vehicle for the purposes of the *Multi-state Class 1 Load Carrying Vehicles Dimension exemption Notice 2016 (No. 1)*, as amended

PART 3 – DIMENSIONS

3.1 Dimension Limits

As far as is practicable, the length and width of a load projecting beyond the rear of the trailer must be minimised. Please refer to **Diagram 1** for more information.

NOTE: *Rear projection (RP) means the distance between the rear of the vehicle and the rear of the load.*

- 3.1.1 The overall height (H) of the combination and its load must not exceed 4.3 metres.
- 3.1.2 The overall width (W) of the combination and its load must not exceed 2.5 metres.

- 3.1.3 The trailer's rear overhang (ROH) must not exceed the lessor of 3.7m or the length of the trailer's front load carrying area.
- 3.1.4 The overall length (OAL) of the combination when loaded must not exceed 19.5 metres.

Diagram 1: Dimensions- Rowing boats

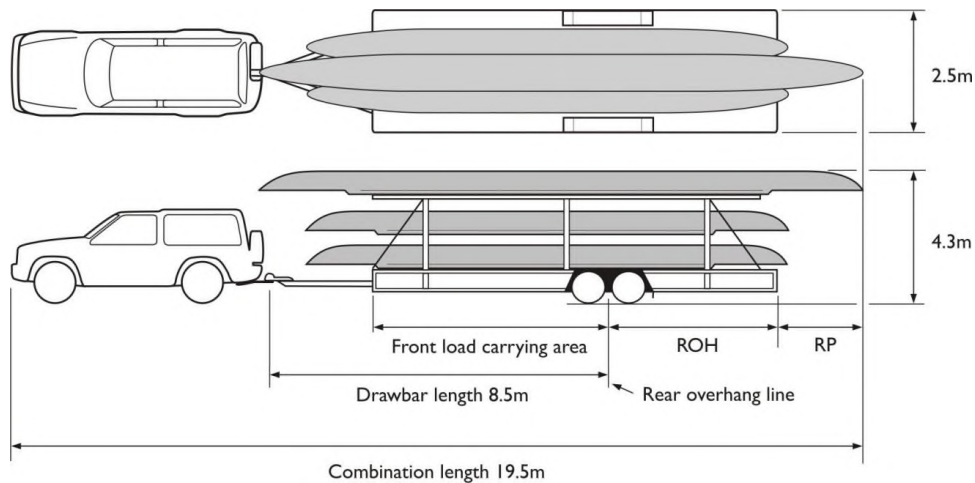

PART 4 – OPERATING, TRAVEL AND OTHER CONDITIONS

4.1 Operating Conditions

- 4.1.1 A copy of this **Notice** must be carried in the driving compartment whenever the combination is operating under this **Notice**, and must be produced when the driver is requested to do so by a police officer or an authorised officer.
- 4.1.2 While operating under this **Notice**, the trailer may only be used for transporting one (or more) of the vessels described in 2.1.1(i)(b) and the equipment necessary for their use.
- 4.1.3 The registered operator of a combination operating under this **Notice** must ensure that the loaded combination can be safely operated on each intended route.
- 4.1.4 The laden mass of the trailer must not exceed the lessor of:
 - (i) the capacity of the towing attachment fitted to the motor vehicle, or
 - (ii) the maximum laden mass or Gross Trailer Mass (GTM) for the trailer.
- 4.1.5 Each component vehicle of the combination must comply in all respects with the requirements for that vehicle under the *Road Transport (Vehicle Registration) Regulation 2017*.
- 4.1.6 If the trailer's mandatory lights or reflectors are obscured by its load, additional lights & reflectors complying with the relevant applicable vehicle standards must be

attached at the rear of the load. Additional lights and reflectors may be attached to a removable light panel.

- 4.1.7 The trailer's number plates must not be obscured and must be visible within an arc of 45 degrees to the top and sides of the plates as shown in **Diagram 2**. If necessary, the number plate must be relocated to the rear of load and provision made to illuminate that number plate.

Diagram 2: Number plate visibility

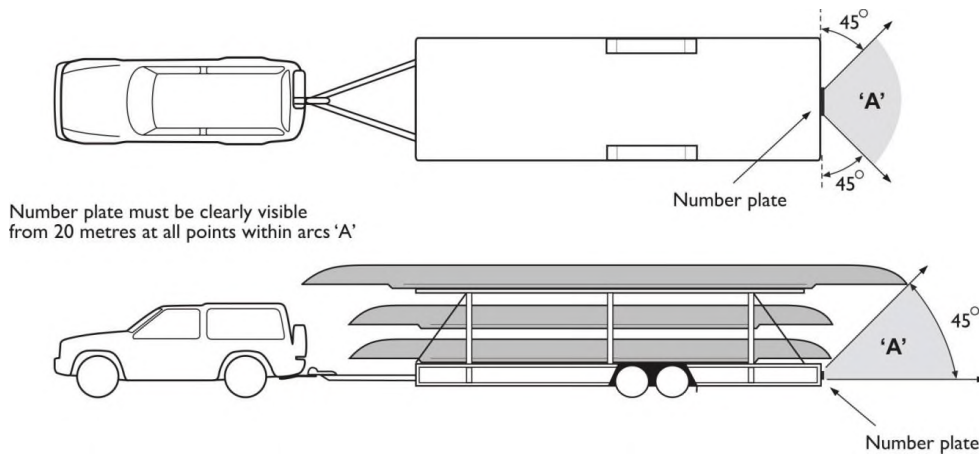

- 4.1.8 If the rear projection of the load (RP) extends past the rear of the trailer by more than 1.2m, there is attached at the load's rear, as a warning to other road users of that projecting load:
 - (i) a device complying with Clause 50L(2)(b), and
 - (ii) if used at night or in hazardous weather conditions causing reduced visibility, a lamp complying with Clause 50L(2)(c).
- 4.1.9 The trailer must be fitted with a DO NOT OVERTAKE TURNING VEHICLE warning sign with a surface area of at least 0.125m² (e.g. 250mm X 500mm) and with characters that are black in colour and in block letters at least 50mm high (see Diagram 3).

Diagram 3: Example of 'DO NOT OVERTAKE TURNING VEHICLE' Sign



- 4.1.10 The trailer must also be fitted with an OVERSIZE vehicle warning sign with a surface area of at least 0.540m² (e.g. 450mm X 1200mm) and with characters that are black in colour and in block letters at least 200mm high (see Diagram 4).

Diagram 4: Example of 'OVERSIZE' vehicle sign



Surface area of plate must be at least 0.540m²

- 4.1.11 Each warning sign must be located as close as possible to the rear of the combination and have a yellow surface complying with Class 1 of Australian/New Zealand Standard AS/NZS 1906.1: 2017 *Retroreflective materials and devices for road control purposes - Retroreflective sheeting*, as amended.

Mining and Petroleum Notices

NOTICE is given that the following application has been received:

EXPLORATION LICENCE APPLICATION

(T17-1234)

No. 5621, LACHLAN RESOURCES PTY LTD (ACN 610 889 882), area of 334 units, for Group 1, dated 7 December, 2017. (Orange Mining Division).

The Honourable Don Harwin MLC
Minister for Resources

NOTICE is given that the following applications have been granted:

EXPLORATION LICENCE APPLICATIONS

(T17-1038)

No. 5452, now Exploration Licence No. 8680, BACCHUS RESOURCES PTY LTD (ACN 606340872), County of Cunningham, Map Sheet (8332), area of 7 units, for Group 1, dated 8 December, 2017, for a term until 8 December, 2022.

(T17-1043)

No. 5457, now Exploration Licence No. 8679, AUSTRALIS AURUM PTY LIMITED (ACN 617 517 969), County of Auckland, Map Sheet (8723, 8823), area of 90 units, for Group 1, dated 8 December, 2017, for a term until 8 December, 2023.

(T17-1088)

No. 5493, now Exploration Licence No. 8680, BACCHUS RESOURCES PTY LTD (ACN 606340872), County of Cunningham, Map Sheet (8332), area of 7 units, for Group 1, dated 8 December, 2017, for a term until 8 December, 2022.

(T17-1126)

No. 5530, now Exploration Licence No. 8678, AUSTRALIAN CONSOLIDATED GOLD HOLDINGS PTY LTD (ACN 619 975 405), County of Georgiana, Map Sheet (8729), area of 35 units, for Group 1 and Group 2, dated 8 December, 2017, for a term until 8 December, 2023.

(T17-1160)

No. 5556, now Exploration Licence No. 8677, HAVERFORD HOLDINGS PTY LTD (ACN 142660553), County of Flinders, Map Sheet (8233, 8234), area of 66 units, for Group 1, dated 8 December, 2017, for a term until 8 December, 2023.

The Honourable Don Harwin MLC
Minister for Resources

NOTICE is given that the following applications for renewal have been received:

(V17-1255)

Exploration Licence No. 5665, PEREGRINE MINERAL SANDS PTY LTD (ACN 009 307 591), area of 40 units. Application for renewal received 18 December, 2017.

(V17-1254)

Mining Lease No. 1409 (Act 1992), CIM STRATFORD PTY LTD (ACN 070 387 914) AND GLOUCESTER COAL LTD (ACN 008 881 712), area of 87.32 hectares. Application for renewal received 18 December, 2017.

(V17-1255)

Mining Purposes Lease No. 109 (Act 1973), ZARIN PTY LTD (ACN 062 716 652), area of 9100 square metres. Application for renewal received 19 December, 2017.

The Honourable Don Harwin MLC
Minister for Resources

RENEWAL OF CERTAIN AUTHORITIES

Notice is given that the following authorities have been renewed:

(V17-8693)

Exploration Licence No. 4848, ROBERT PATRICK HEWETT, County of Hawes, Map Sheet (9234), area of 1 units, for a further term until 31 May, 2021. Renewal effective on and from 8 December, 2017.

(Z16-0519)

Exploration Licence No. 5460, ANGLO COAL (DRAYTON SOUTH) PTY LTD (ACN 081 072 755), ANGLO COAL (DRAYTON) NO. 2 PTY LIMITED (ACN 004 917 177), DAESUNG AUSTRALIA PTY LIMITED (ACN 002 011 967), HYUNDAI AUSTRALIA PTY LTD (ACN 002 008 657), MITSUI DRAYTON INVESTMENT PTY LTD (ACN 082 138 529) AND NCE AUSTRALIA PTY LTD (ACN 001 799 444), County of Durham, Map Sheet (9033), area of 5580 hectares, for a further term until 2 April, 2022. Renewal effective on and from 8 December, 2017.

(V17-4958)

Exploration Licence No. 5583, TRIAUSMIN PTY LTD (ACN 062 002 475), Counties of Bathurst and Wellington, Map Sheet (8731), area of 51 units, for a further term until 25 June, 2022. Renewal effective on and from 15 November, 2017.

(V17-0342)

Exploration Licence No. 5674, SILVER MINES LIMITED (ACN 107 452 942), County of Gough, Map Sheet (9239), area of 4 units, for a further term until 13 January, 2023. Renewal effective on and from 20 November, 2017.

(V17-8984)

Exploration Licence No. 6304, DONALD JOHN PERKIN, County of Roxburgh, Map Sheet (8831), area of 24 units, for a further term until 24 September, 2019. Renewal effective on and from 24 November, 2017.

(V17-9173)

Exploration Licence No. 6622, BROKEN HILL PROSPECTING LIMITED (ACN 003 453 503), County of Yancowinna, Map Sheet (7133), area of 17 units, for a further term until 30 August, 2020. Renewal effective on and from 15 November, 2017.

(V17-1053)

Exploration Licence No. 6901, CARPENTARIA RESOURCES LIMITED (ACN 095117981), County of Bland, Map Sheet (8429), area of 21 units, for a further term until 8 October, 2020. Renewal effective on and from 20 November, 2017.

(V17-3415)

Exploration Licence No. 7134, ARGENT (KEMPFIELD) PTY LTD (ACN 155 759 550), Counties of Bathurst and Georgiana, Map Sheet (8730), area of 10 units, for a further term until 30 April, 2020. Renewal effective on and from 17 November, 2017.

(T09-0097)

Exploration Licence No. 7398, ZEOLITE ENVIRONMENTAL GLOBAL SOLUTIONS PTY LTD (ACN 127 127 815), Counties of Buckland and Parry, Map Sheet (9035), area of 4 units, for a further term until 23 September, 2020. Renewal effective on and from 17 November, 2017.

(V17-3880)

Exploration Licence No. 7941, OCHRE RESOURCES PTY LTD (ACN 112 833 351), Counties of Cunningham and Flinders, Map Sheet (8233), area of 5 units, for a further term until 23 May, 2022. Renewal effective on and from 27 November, 2017.

(T12-1175)

Exploration Licence No. 8213, ARGENT (KEMPFIELD) PTY LTD (ACN 155 759 550), County of Georgiana, Map Sheet (8730), area of 18 units, for a further term until 12 December, 2019. Renewal effective on and from 16 November, 2017.

(V17-3738)

Exploration Licence No. 8267, OCHRE RESOURCES PTY LTD (ACN 112 833 351), Counties of Cunningham, Flinders and Mouramba, Map Sheet (8133, 8134, 8233, 8234), area of 85 units, for a further term until 12 May, 2020. Renewal effective on and from 17 November, 2017.

(T17-1148)

Exploration Licence No. 8285, ALPINE MEADOWS CLEAN-FILL PTY LTD (ACN 148 993 426), Counties of Canbelego and Flinders, Map Sheet (8234), area of 4 units, for a further term until 6 August, 2020. Renewal effective on and from 16 November, 2017.

(V17-8377)

Exploration Licence No. 8286, CLAYSTONE MASONRY PTY LTD (ACN 081802879), Counties of Burnett and Murchison, Map Sheet (9038), area of 15 units, for a further term until 8 August, 2023. Renewal effective on and from 16 November, 2017.

(V17-8872)

Exploration Licence No. 8290, FISHER RESOURCES PTY LTD (ACN 148 160 954), County of Blaxland, Map Sheet (8031, 8032), area of 45 units, for a further term until 20 August, 2020. Renewal effective on and from 27 November, 2017.

(T17-1178)

Exploration Licence No. 8475, ALLOY MINERALS PTY LTD (ACN 611 918 846), Counties of Menindee and Yancowinna, Map Sheet (7133), area of 91 units, for a further term until 21 October, 2020. Renewal effective on and from 19 December, 2017.

(V17-8700)

Exploration (Prospecting) Licence No. 1094, ROBERT PATRICK HEWETT, County of Hawes, Map Sheet (9234), area of 2 units, for a further term until 19 August, 2021. Renewal effective on and from 8 December, 2017.

(V17-9323)

Consolidated Mining Lease No. 7 (Act 1992), PEAK GOLD MINES PTY LTD (ACN 001 533 777), Parish of Weltie, County of Robinson, Map Sheet (8034-1-N), area of 1185.5 hectares, for a further term until 28 June, 2025. Renewal effective on and from 8 December, 2017.

(T92-0336)

Mining Purposes Lease No. 346 (Act 1973), LIGHTNING RIDGE MINERS' ASSOCIATION LTD (ACN 001 204 726), Parish of Langloh, County of Finch, Map Sheet (8439-2-S), area of 8.008 hectares, for a further term until 20 June, 2022. Renewal effective on and from 27 November, 2017.

The Honourable Don Harwin MLC
Minister for Resources

CANCELLATION OF MINING LEASES FOR FAILURE TO COMPLY WITH CONDITIONS OF THE LEASE OR MINING ACT

Notice is given that the following leases have been cancelled:

(Z94-0432)

Mining Lease No. 56 (Act 1973), FAR WESTERN STONE QUARRIES PTY LTD (ACN 000 734 341), Parish of Fords Bridge, County of Gunderbooka, Map Sheet (8038-3-N), area of 26.95 hectares. Cancellation took effect on 15 December, 2017.

(Z94-0432)

Mining Lease No. 57 (Act 1973), FAR WESTERN STONE QUARRIES PTY LTD (ACN 000 734 341), Parish of Fords Bridge, County of Gunderbooka, Map Sheet (8038-3-N), area of 26.95 hectares. Cancellation took effect on 15 December, 2017.

(Z94-0432)

Mining Lease No. 620 (Act 1973), FAR WESTERN STONE QUARRIES PTY LTD (ACN 000 734 341), Parish of Fords Bridge, County of Gunderbooka, Map Sheet (8038-3-N), area of 13.47 hectares. Cancellation took effect on 15 December, 2017.

The Honourable Don Harwin MLC
Minister for Resources

TRANSFER APPLICATION

(V17-1255)

Mining Purposes Lease No. 109 (Act 1973), ZARIN PTY LTD (ACN 062 716 652) to VINKOVIC, Vladimir, County of Finch, area of 9100 square metres. Application for transfer received 19 December, 2017.

The Honourable Don Harwin MLC
Minister for Resources

Energy Notices

ELECTRICITY SUPPLY ACT 1995 (NSW)

ENERGY SAVINGS SCHEME (ELECTRICITY LOAD EXEMPTIONS) ORDER 2017

I, Don Harwin MLC, Minister for Energy and Utilities, in pursuance of sections 119(1)(b) and 122(2) of the *Electricity Supply Act 1995* (NSW) (the Act) and being satisfied that each electricity load to which this Order applies is used in connection with an industry or activity that is both emissions intensive and trade exposed and that the exemptions are generally consistent with the objects of Part 9 of the Act, make the following Order.

Dated this 15th day of December 2017.

DON HARWIN, MLC
Minister for Energy and Utilities

Explanatory note

The objects of this Order are:

- (a) to grant exemptions from the Energy Savings Scheme in respect of any electricity load used in connection with a specified activity, and
- (b) to specify allowances that may be made by scheme participants in applying the exemptions, and
- (c) to authorise the Scheme Regulator to make rules with respect to the exemptions granted by this Order (including rules relating to the assessment of deductions under Division 5 of Part 9 of the Act), and
- (d) to revoke the previous order granting exemptions from the Energy Savings Scheme published on 12th December 2016.

This Order is made under sections 119(1)(b) and 122(2) of the Act.

1 Name of Order

This Order is the *Energy Savings Scheme (Electricity Load Exemptions) Order 2017*.

2 Commencement

This Order commences on 1 January 2018.

3 Exemptions

- (1) Any electricity load used in connection with a specified activity set out in Column 1 of Schedule 1, at the corresponding location specified in Column 2 of Schedule 1, is either fully or partially exempt from the Energy Savings Scheme in Part 9 of the Act as specified in Column 3 of Schedule 1.
- (2) For partial exemptions, the exemption proportion of each electricity load is specified in Column 4 of Schedule 1 (expressed as a percentage).

4 Allowances

In applying an exemption granted by this Order, a scheme participant may deduct from the total value of its liable acquisitions an allowance of 5% of the exempt proportion (specified in Column 4 of Schedule 1) for electricity losses occurring between the purchase of the electricity by the scheme participant and its use.

5 Rules

The Scheme Regulator is authorised to make rules with respect to the exemptions granted by this Order (including rules relating to the assessment of deductions under Division 5 of Part 9 of the Act).

6 Revocation

- (1) The order made under section 119 of the Act dated 12 December 2016 and published in NSW Government Gazette No 117 of 16 December 2016, pages 3639 – 3643, is revoked.
- (2) In accordance with section 122(3) of the Act, this revocation will take effect on 1 January 2018.

Schedule 1 Table of Exemptions

Column 1 Specified Activity	Column 2 Location (address)	Column 3 Type of exemption	Column 4 Exempt proportion (for partial exemptions)	Reference
Tissue paper manufacturing	63-65 Redfern Street WETHERILL PARK NSW 2164	Partial Exemption	90%	A.B.C. Paper & Paper Mills Pty. Limited ABN 41 003 879 098
Production of glass containers	5 Andrews Road PENRITH NSW 2750	Partial Exemption	90%	ACI Operations Pty. Ltd. (t/a O-I Australia) ABN 94 004 230 326
Integrated iron and steel manufacturing	Five Islands Road PORT KEMBLA NSW 2505	Partial Exemption	90%	BlueScope Steel (AIS) Pty. Ltd. ABN 19 000 019 625
Production of clinker	Taylor Avenue NEW BERRIMA NSW 2577	Partial Exemption	90%	Boral Shared Business Services Pty Ltd ABN 31 000 373 660
Manufacture of reconstituted wood-based panels	Mount Lowes Road OBERON NSW 2787	Partial Exemption	90%	Borg Manufacturing Pty Limited ABN <u>31 003 246 357</u>
Manufacture of reconstituted wood-based panels	Lowes Mount Road OBERON NSW 2787	Partial Exemption	90%	Carter Holt Harvey Pinepanels Pty Limited ABN 51 107 211 567
Manufacture of reconstituted wood-based panels	Jepsen Avenue TUMUT NSW 2720	Partial Exemption	90%	Carter Holt Harvey Pinepanels Pty Limited ABN 51 107 211 567
Production of magnesia	2 Park Avenue YOUNG NSW 2594	Partial Exemption	90%	Causmag Ore Company Proprietary Limited ABN 73 004 301 517
Manufacture of carbon steel from cold ferrous feed	2 Maud Street WARATAH NSW 2298	Partial Exemption	90%	Commonwealth Steel Company Pty Limited ABN 58 000 007 698
Production of glass wool	55 Stennett Road INGLEBURN NSW 2565	Partial Exemption	90%	CSR Building Products Limited ABN 55 008 631 356
Production of glass wool	600 Woodstock Avenue ROOTY HILL NSW 2766	Partial Exemption	90%	Fletcher Building (Australia) Pty Ltd ABN 11 093 539 452
Production of high purity ethanol	36 Bolong Road BOMBADERRY NSW 2541	Partial Exemption	90%	Honan Holdings Pty Ltd ABN 31 000 392 727
Production of dried distillers grains with solubles	36 Bolong Road BOMBADERRY NSW 2541	Partial Exemption	90%	Honan Holdings Pty Ltd ABN 31 000 392 727
Production of chlorine gas and sodium hydroxide (caustic soda) solution	16-20 Beauchamp Road MATRAVILLE NSW 2036	Partial Exemption	90%	Ixom Operations Pty Ltd ABN 51 600 546 512
Rendering of animal by-products	Muffett Street SCONE NSW 2337	Partial Exemption	90%	JBS Australia Pty Limited ABN 14 011 062 338

Column 1 Specified Activity	Column 2 Location (address)	Column 3 Type of exemption	Column 4 Exempt proportion (for partial exemptions)	Reference
Rendering of animal by-products	Regulator Road YANCO NSW 2703	Partial Exemption	90%	JBS Australia Pty Limited ABN 14 011 062 338
Production of ceramic floor and wall tiles	175 Racecourse Road RUTHERFORD NSW 2320	Partial Exemption	90%	National Ceramic Industries Australia Pty Limited ABN 83 100 467 267
Manufacture of newsprint	117 R W Henry Drive ETTAMOGAH NSW 2640	Partial Exemption	90%	Norske Skog Paper Mills (Australia) Limited ABN 84 009 477 132
Manufacture of carbon steel from cold ferrous feed	Ingall Street MAYFIELD EAST NSW 2304	Partial Exemption	90%	OneSteel Manufacturing Pty Limited ABN 42 004 651 325
Integrated iron and steel manufacturing	Ingall Street MAYFIELD EAST NSW 2304	Partial Exemption	90%	OneSteel Manufacturing Pty Limited 42 004 651 325
Manufacture of carbon steel from cold ferrous feed	22 Kellogg Road ROOTY HILL NSW 2766	Partial Exemption	90%	OneSteel NSW Pty Limited ABN 59 003 312 892
Integrated iron and steel manufacturing	22 Kellogg Road ROOTY HILL NSW 2766	Partial Exemption	90%	OneSteel NSW Pty Limited ABN 59 003 312 892
Production of ammonium nitrate	15 Greenleaf Road KOORAGANG ISLAND NSW 2304	Partial Exemption	90%	Orica Australia Pty Ltd ABN 99 004 117 828
Production of ammonia	15 Greenleaf Road KOORAGANG ISLAND NSW 2304	Partial Exemption	90%	Orica Australia Pty Ltd ABN 99 004 117 828
Packaging and industrial paper manufacturing	1891 Botany Road MATRAVILLE NSW 2036	Partial Exemption	90%	Orora Limited 55 004 275 165
Production of polymer grade propene (polymer grade propylene)	16-20 Beauchamp Road BOTANY NSW 2036	Partial Exemption	90%	Qenos Pty Ltd ABN 62 054 196 771
Production of polyethylene	16-20 Beauchamp Road BOTANY NSW 2036	Partial Exemption	90%	Qenos Pty Ltd ABN 62 054 196 771
Production of ethene (ethylene)	16-20 Beauchamp Road BOTANY NSW 2036	Partial Exemption	90%	Qenos Pty Ltd ABN 62 054 196 771
Production of lime	Garthowen Road ATTUNGA NSW 2345	Partial Exemption	90%	Sibelco Australia Limited ABN 20 000 971 844
Production of lime	Eubindal Road GALONG NSW 2585	Partial Exemption	90%	Sibelco Australia Limited ABN 20 000 971 844

Column 1 Specified Activity	Column 2 Location (address)	Column 3 Type of exemption	Column 4 Exempt proportion (for partial exemptions)	Reference
Production of hydrogen peroxide	20-22 McPherson Street BANKSMEADOW NSW 2019	Partial Exemption	90%	Solvay Interlox Pty. Ltd. ABN 70 000 882 137
Production of high purity ethanol	Beelgangera Road BEELGANGERA NSW 2680	Partial Exemption	90%	Tarac Technologies Pty Ltd ABN 28 007 513 813
Rendering of animal by-products	Dampier Street WAGGA WAGGA NSW 2650	Partial Exemption	90%	Teys Australia Southern Pty Ltd ABN 53 084 034 695
Rendering of animal by-products	Phoenix Street TAMWORTH NSW 2340	Partial Exemption	90%	Teys Australia Southern Pty Ltd ABN 53 084 034 695
Rendering of animal by-products	Phoenix Street TAMWORTH NSW 2340	Partial Exemption	90%	Thomas Foods International Tamworth Pty Limited ABN 82 089 140 634
Aluminium smelting	638 Tomago Road TOMAGO NSW 2322	Partial Exemption	90%	Tomago Aluminium Company Pty Ltd ABN 68 001 862 228
Packaging and industrial paper manufacturing	158 Mccredie Rd SMITHFIELD NSW 2164	Partial Exemption	90%	Visy Industries Australia Pty Ltd ABN 74 004 337 615
Packaging and industrial paper manufacturing	436 Gadara Rd TUMUT NSW 2720	Partial Exemption	90%	Visy Industries Australia Pty Ltd ABN 74 004 337 615

Primary Industries Notices

BIOSECURITY ACT 2015

Instrument of Appointment of Authorised Officers and Approval of Functions
– Department of Primary Industries and Local Land Services officers

I, Peter Day, Director Biosecurity & Food Safety Compliance, in exercise of delegated authority of the Secretary and of the Secretary as Accreditation Authority under the *Biosecurity Act 2015* (the Act) make the following appointments and approvals:

- 1) Pursuant to section 361 of the Act, I appoint the persons listed in Column 1 of the table set out in Schedule 1 as authorised officers for the purposes of the Act.
- 2) Pursuant to section 195 of the Act, I approve those authorised officers listed in Column 1 of the table set out in Schedule 1 to exercise the functions of a biosecurity certifier as specified in Column 2 of the table.

Duration of appointment and approval:

The appointment and approval of each person listed in Schedule 1 will end on the earliest of the following dates:

- A. the date that is five years from the date of this instrument; or
- B. the date of revocation of this instrument, or an instrument of revocation of appointment of a person listed in Schedule 1 as an authorised officer; or
- C. the date that the person ceases to be employed by either the Department of Industry or the Local Land Services.

Dated this 19th day of December 2017

PETER DAY

PETER DAY

DIRECTOR

BIOSECURITY & FOOD SAFETY COMPLIANCE

(as delegate on behalf of the Secretary of the Department of Industry)

SCHEDULE 1

Column 1	Column 2
Name of person appointed as authorised officer	Approved functions of biosecurity certifier
Eve Hall	NIL Conditions

FISHERIES MANAGEMENT ACT 1994

Section 8 Notification – Fishing Closure

Pipi (*Donax deltoideus*)

I, GEOFFREY ALLAN, Deputy Director General Fisheries, with the delegated authority of the Minister for Primary Industries and the Secretary of the Department of Industry pursuant to sections 227 and 228 of the *Fisheries Management Act 1994* (“the Act”), do by this notification pursuant to section 8 of the Act, prohibit the taking of pipis (*Donax deltoideus*), by holders of a hand gathering endorsement in the Estuary General Fishery, by the methods of fishing specified in Column 1 of Schedule 1 to this notification, from the waters described opposite in Column 2 of Schedule 1 to this notification.

Column 1 Methods	d Column 2 Waters
By means of hand picking as prescribed by section 6D of Schedule 1 to the Act.	All waters.

In this fishing closure:

Estuary General Fishery means the share management fishery of that name, as described in Schedule I to the Act.

This fishing closure notification is effective for a period of five (5) months commencing on 1 January 2018 unless sooner amended or revoked.

Dated this 12th day of December 2017.

Dr Geoffrey Allan
Deputy Director General Fisheries
Department of Primary Industries
(an office within the Department of Industry)

FISHERIES MANAGEMENT ACT 1994

Notice of Determination – Total Allowable Catch for Abalone

I, NIALL MARK BLAIR MLC, Minister for Primary Industries, pursuant to section 40H of the *Fisheries Management Act 1994* (“the Act”),

1. give notice that on 22 November 2017 the Total Allowable Fishing Committee determined, pursuant to section 40D of the Act and clause 14 of the Appendix to the *Fisheries Management (Abalone Share Management Plan) Regulation 2000*, that the total allowable catch for abalone for the fishing period 1 January 2018 to 31 December 2018 (both dates inclusive) is 100 tonnes
2. note that pursuant to section 40H(3) of the Act, the determination published in Government Gazette No. 120 of 23 December 2016 at page 3799 is revoked.

Dated this 20th day of December 2017

The Hon Niall Blair MLC
Minister for Primary Industries
Minister for Regional Water
Minister for Trade and Industry

Crown Land Notices

1300 886 235 www.crownland.nsw.gov.au

NOTIFICATION OF CLOSING OF A ROAD

In pursuance of the provisions of the *Roads Act 1993*, the road hereunder described is closed and the lands comprised therein cease to be public road and the rights of passage and access that previously existed in relation to the road is extinguished. Upon closing, title to the land, comprising the former public road, vests in the body specified in the Schedule hereunder.

The Hon Paul Toole, MP
Minister for Lands and Forestry

DESCRIPTION

Parish – King; County – Selwyn

Land District – Tumbarumba; LGA – Snowy Valleys

Road Closed: Lot 3 DP 1236464

File No: 17/06102

SCHEDULE

On closing, the land within Lot 3 DP 1236464 remains vested in the State of New South Wales as Crown land.

NOTIFICATION OF CLOSING OF A ROAD

In pursuance of the provisions of the *Roads Act 1993*, the road hereunder described is closed and the lands comprised therein cease to be public road and the rights of passage and access that previously existed in relation to the road is extinguished. Upon closing, title to the land, comprising the former public road, vests in the body specified in the Schedule hereunder.

The Hon Paul Toole, MP
Minister for Lands and Forestry

DESCRIPTION

Parishes – Cunningar, Murrumboola; County – Harden

Land District – Young; LGA – Hilltops

Road Closed: Lot 5 DP 1236412

File No: 17/04696

SCHEDULE

On closing, the land within Lot 5 DP 1236412 remains vested in the State of New South Wales as Crown land.

NOTIFICATION OF CLOSING OF A ROAD

In pursuance of the provisions of the *Roads Act 1993*, the road hereunder described is closed and the lands comprised therein cease to be public road and the rights of passage and access that previously existed in relation to the road is extinguished. Upon closing, title to the land, comprising the former public road, vests in the body specified in the Schedule hereunder.

The Hon Paul Toole, MP
Minister for Lands and Forestry

DESCRIPTION

Parish – Elrington; County – St Vincent

Land District – Braidwood; LGA – Queanbeyan-Palerang Regional

Road Closed: Lot 1 DP 1236857

File No: 17/05329

SCHEDULE

On closing, the land within Lot 1 DP 1236857 remains vested in the State of New South Wales as Crown land.

NOTIFICATION OF CLOSING OF A ROAD

In pursuance of the provisions of the *Roads Act 1993*, the road hereunder described is closed and the lands comprised therein cease to be public road and the rights of passage and access that previously existed in relation to the road is extinguished. Upon closing, title to the land, comprising the former public road, vests in the body specified in the Schedule hereunder.

The Hon Paul Toole, MP
Minister for Lands and Forestry

DESCRIPTION

Parish – Woodford; County – Clarence
Land District – Grafton; LGA – Clarence Valley

Road Closed: Lot 3 DP 1236907

File No: 17/05917

SCHEDULE

On closing, the land within Lot 3 DP 1236907 remains vested in the State of New South Wales as Crown land.

NOTIFICATION OF CLOSING OF A ROAD

In pursuance of the provisions of the *Roads Act 1993*, the road hereunder described is closed and the lands comprised therein cease to be public road and the rights of passage and access that previously existed in relation to the road is extinguished. Upon closing, title to the land, comprising the former public road, vests in the body specified in the Schedule hereunder.

The Hon Paul Toole, MP
Minister for Lands and Forestry

DESCRIPTION

Parish – Tootool; County – Mitchell
Land District – Wagga Wagga; LGA – Lockhart

Road Closed: Lot 3 DP 1226605

File No: 15/03054

SCHEDULE

On closing, the land within Lot 3 DP 1226605 remains vested in the State of New South Wales as Crown land.

NOTIFICATION OF CLOSING OF A ROAD

In pursuance of the provisions of the *Roads Act 1993*, the road hereunder described is closed and the lands comprised therein cease to be public road and the rights of passage and access that previously existed in relation to the road is extinguished. Upon closing, title to the land, comprising the former public road, vests in the body specified in the Schedule hereunder.

The Hon Paul Toole, MP
Minister for Lands and Forestry

DESCRIPTION

Parish – Bullenbung; County – Mitchell
Land District – Wagga Wagga; LGA – Wagga Wagga

Road Closed: Lot 2 DP 1226606

File No: 15/03053

SCHEDULE

On closing, that part of the land within Lot 2 DP 1226606 which was formerly Crown road remains vested in the State of New South Wales as Crown land.

On closing, that part of the land within Lot, 2 DP1226606 which was formerly Council road becomes vested in the State of New South Wales as Crown Land.

NOTIFICATION OF CLOSING OF A ROAD

In pursuance of the provisions of the *Roads Act 1993*, the road hereunder described is closed and the lands comprised therein cease to be public road and the rights of passage and access that previously existed in relation to the road is extinguished. Upon closing, title to the land, comprising the former public road, vests in the body specified in the Schedule hereunder.

The Hon Paul Toole, MP
Minister for Lands and Forestry

DESCRIPTION

Parish – Hillas; County – Wynyard

Land District – Tumbarumba; LGA – Snowy Valleys

Road Closed: Lots 1-2 DP 1234630

File No: 17/06284

SCHEDULE

On closing, the land within Lots 1 DP 1234630 remains vested in the State of New South Wales as Crown land.

On closing, the land within Lot 2 DP1234630 which was formerly Council road becomes vested in the State of New South Wales as Crown Land. On closing, the land within Lot 2 DP127897 remains vested in the State of New South Wales as Crown land.

NOTIFICATION OF CLOSING OF A ROAD

In pursuance of the provisions of the *Roads Act 1993*, the road hereunder described is closed and the lands comprised therein cease to be public road and the rights of passage and access that previously existed in relation to the road is extinguished. Upon closing, title to the land, comprising the former public road, vests in the body specified in the Schedule hereunder.

The Hon Paul Toole, MP
Minister for Lands and Forestry

DESCRIPTION

Parish – Kolkilbertoo South; County – Cooper

Land District – Narrandera; LGA – Bland

Road Closed: Lot 1 DP 1234214

File No: 17/02199

SCHEDULE

On closing, the land within Lot 1 DP 1234214 remains vested in the State of New South Wales as Crown land.

NOTIFICATION OF CLOSING OF A ROAD

In pursuance of the provisions of the *Roads Act 1993*, the road hereunder described is closed and the lands comprised therein cease to be public road and the rights of passage and access that previously existed in relation to the road is extinguished. Upon closing, title to the land, comprising the former public road, vests in the body specified in the Schedule hereunder.

The Hon Paul Toole, MP
Minister for Lands and Forestry

DESCRIPTION

Parish – Yarrowford; County – Gough
Land District – Glen Innes; LGA – Glen Innes Severn

Road Closed: Lot 5 DP 1235075

File No: 17/06136

SCHEDULE

On closing, the land within Lot 5 DP 1235075 remains vested in the State of New South Wales as Crown land.

ROADS ACT 1993 – ORDER

TRANSFER OF A CROWN ROAD TO COUNCIL

In pursuance of the provisions of section 151, *Roads Act 1993*, the Crown road specified in Schedule 1 is transferred to the Roads Authority specified in Schedule 2, as from the date of publication of this notice and as from the date the road specified in Schedule 1 ceases to be a Crown road.

The Hon Paul Toole, MP
Minister for Lands and Forestry

SCHEDULE 1

Parish – Byron; County – Rous
Land District – Lismore; LGA – Byron

Crown public road known as Melaleuca Drive at Byron Bay adjacent to western boundary of Lot 1 DP542178 as shown by solid black shading on the diagram hereunder.



SCHEDULE 2

Roads Authority: Byron Shire Council

File No: 16/08769

NOTIFICATION OF CLOSING OF A ROAD

In pursuance of the provisions of the *Roads Act 1993*, the road hereunder described is closed and the lands comprised therein cease to be public road and the rights of passage and access that previously existed in relation to the road is extinguished. Upon closing, title to the land, comprising the former public road, vests in the body specified in the Schedule hereunder.

The Hon Paul Toole, MP
Minister for Lands and Forestry

DESCRIPTION

Parish – Stockrington; County – Northumberland
Land District – Maitland; LGA – Cessnock

Road Closed: Lot 1 DP 1237043

File No: 17/08350

SCHEDULE

On closing, the land within Lot 1 DP 1237043 remains vested in the State of New South Wales as Crown land.

NOTIFICATION OF CLOSING OF A ROAD

In pursuance of the provisions of the *Roads Act 1993*, the road hereunder described is closed and the lands comprised therein cease to be public road and the rights of passage and access that previously existed in relation to the road is extinguished. Upon closing, title to the land, comprising the former public road, vests in the body specified in the Schedule hereunder.

The Hon Paul Toole, MP
Minister for Lands and Forestry

DESCRIPTION

Parish – Gulligal; County – Darling
Land District – Tamworth; LGA – Tamworth Regional

Road Closed: Lot 1 DP 1218931

File No: TH06H34

SCHEDULE

On closing, the land within Lot 1 DP 1218931 remains vested in the State of New South Wales as Crown land.

NOTIFICATION OF CLOSING OF A ROAD

In pursuance of the provisions of the *Roads Act 1993*, the road hereunder described is closed and the lands comprised therein cease to be public road and the rights of passage and access that previously existed in relation to the road is extinguished. Upon closing, title to the land, comprising the former public road, vests in the body specified in the Schedule hereunder.

The Hon Paul Toole, MP
Minister for Lands and Forestry

DESCRIPTION

Parish – Coolac; County – Harden
Land District – Gundagai; LGA – Cootamundra-Gundagai Regional

Road Closed: Lots 1-2 DP 1236718

File No: 17/06489

SCHEDULE

On closing, the land within Lots 1 DP 1236718 remains vested in the State of New South Wales as Crown land.

On closing, the land within Lot, 2 DP1236718 becomes vested in the State of New South Wales as Crown Land.

NOTIFICATION OF CLOSING OF A ROAD

In pursuance of the provisions of the *Roads Act 1993*, the road hereunder described is closed and the lands comprised therein cease to be public road and the rights of passage and access that previously existed in relation to the road is extinguished. Upon closing, title to the land, comprising the former public road, vests in the body specified in the Schedule hereunder.

The Hon Paul Toole, MP
Minister for Lands and Forestry

DESCRIPTION

Parish – Gungewalla; County – Monteagle
Land District – Boorowa; LGA – Hilltops

Road Closed: Lot 1 DP 1234059

File No: 16/09674

SCHEDULE

On closing, the land within Lot 1 DP 1234059 remains vested in the State of New South Wales as Crown land.

NOTIFICATION OF CLOSING OF A ROAD

In pursuance of the provisions of the *Roads Act 1993*, the road hereunder described is closed and the lands comprised therein cease to be public road and the rights of passage and access that previously existed in relation to the road is extinguished. Upon closing, title to the land, comprising the former public road, vests in the body specified in the Schedule hereunder.

The Hon Paul Toole, MP
Minister for Lands and Forestry

DESCRIPTION

Parish – Gungewalla; County – Monteagle

Land District – Boorowa; LGA – Hilltops

Road Closed: Lot 1 DP 1234059

File No: 16/09674

SCHEDULE

On closing, the land within Lot 1 DP 1234059 remains vested in the State of New South Wales as Crown land.

NOTIFICATION OF CLOSING OF A ROAD

In pursuance of the provisions of the *Roads Act 1993*, the road hereunder described is closed and the lands comprised therein cease to be public road and the rights of passage and access that previously existed in relation to the road is extinguished. Upon closing, title to the land, comprising the former public road, vests in the body specified in the Schedule hereunder.

The Hon Paul Toole, MP
Minister for Lands and Forestry

DESCRIPTION

Parish – Berwick; County – Rous

Land District – Murwillumbah; LGA – Tweed

Road Closed: Lot 1 DP 1223650

File No: 15/10932

SCHEDULE

On closing, the land within Lot 1 DP 1223650 remains vested in the State of New South Wales as Crown land.

NOTIFICATION OF CLOSING OF A ROAD

In pursuance of the provisions of the *Roads Act 1993*, the road hereunder described is closed and the lands comprised therein cease to be public road and the rights of passage and access that previously existed in relation to the road is extinguished. Upon closing, title to the land, comprising the former public road, vests in the body specified in the Schedule hereunder.

The Hon Paul Toole, MP
Minister for Lands and Forestry

DESCRIPTION

Parish – Congera; County – Monteagle

Land District – Boorowa; LGA – Hilltops

Road Closed: Lots 1-2 DP 1236668

File No: 17/05614

SCHEDULE

On closing, the land within Lots 1-2 DP 1236668 remains vested in the State of New South Wales as Crown land.

ROADS ACT 1993

ORDER

Transfer of a Crown Road to a Council

IN pursuance of the provisions of section 151, *Roads Act 1993*, the Crown road specified in Schedule 1 is transferred to the Roads Authority specified in Schedule 2 hereunder, as from the date of publication of this notice and as from that date the roads specified in Schedule 1 cease to be a Crown road.

The Hon Paul Toole, MP
Minister for Lands and Water

Schedule 1

Parish – Currawong; County – Canbelego

Land District – Nyngan; LGA – Bogan Shire Council

Crown road highlighted red on diagram hereunder.



Schedule 2

Road Authority: Bogan Shire Council

File Ref: 17/11654 – W592552

Council Ref: Cluster 581125

NOTIFICATION OF CLOSING OF A ROAD

In pursuance of the provisions of the *Roads Act 1993*, the road hereunder described is closed and the lands comprised therein cease to be public road and the rights of passage and access that previously existed in relation to the road is extinguished. Upon closing, title to the land, comprising the former public road, vests in the body specified in the Schedule hereunder.

The Hon Paul Toole, MP
Minister for Lands and Forestry

DESCRIPTION

Parish – Fairy Mount; County – Rous

Land District – Casino; LGA – Kyogle

Road Closed: Lot 5 DP 1236155

File No: 16/10609

SCHEDULE

On closing, the land within Lot 5 DP 1236155 remains vested in the State of New South Wales as Crown land.

NOTIFICATION OF CLOSING OF A ROAD

IN pursuance of the provisions of the *Roads Act 1993*, the roads described in Column 1 of the Schedule hereunder are closed and the lands comprised therein cease to be public road and the rights of passage and access that previously existed in relation to the roads are extinguished. Upon closing the roads described in Column 1 the lands defined in Column 5 of the Schedule being the re-defined roads will be dedicated as public road.

The Hon. Paul Toole M.P.
Minister for Lands and Forestry

Description

Parishes & Counties – Varies

Land District – Varies

LGA – Wentworth

Column 1 Western Division Road (WDR) No. & Deposited Plan (DP)	Column 2 Gazetted Public Road	Column 3 Road Name	Column 4 Within Lot/DP	Column 5 Legal Roads Network Deposited Plan (DP) No.
141 (DP97141)	12 November 1982	Garnpang Road	3618/765970	1193988
141 (DP97141)	12 November 1982	Garnpang Road	3620/765972	1193988
141 (DP97141)	12 November 1982	Garnpang Road	6124/48783	1193988
141 (DP97141)	12 November 1982	Garnpang Road	6120/48783	1193988
141 (DP97141)	12 November 1982	Gol Gol Road	6121/48783	1193988
150 (DP97150)	18 February 1983	Dockerty Road	368/761065	1193988

File No.: 14/00186

ADDITION OF LANDS TO A WESTERN LANDS LEASE

IT is hereby notified that in pursuance of Section 35C of the *Western Lands Act 1901*, the land particularised in Column 3, being the road closed in Column 4, has been added to the Western Lands Leases identified in Column 1.

The Hon. Paul Toole M.P.
Minister for Lands and Forestry

Description

Parishes – Varies Counties – Varies

Land District – Varies

LGA – Wentworth

Column 1 Western Lands Lease No.	Column 2 Folio ID	Column 3 Area Addition (ha)	Column 4 Former WDR No	Column 5 Total Area following Addition (ha)
3002	6124/48783	47.78	141	9181
6288	3618/765970	3.906	141	7912
6290	3620/765972	30.73	141	7816
14314	6120/48783	34.66	141	6914
14316	6121/48783	46.36	141	6610
2164	368/761065	39	150	14844

File No.: 14/00186

WITHDRAWAL OF LANDS FROM WESTERN LANDS LEASES

IT is hereby notified that in pursuance of Section 35Q of the *Western Lands Act 1901*, the land particularised in Column 1 has been withdrawn from the Western Lands Leases identified in Column 2 for the purpose of being dedicated as public road.

The Hon. Paul Toole M.P.
Minister for Lands and Forestry

Description

Parishes – Varies Counties – Varies

Land District – Varies

LGA – Wentworth

Column 1	Column 2	Column 3	Column 4	Column 5
Land Withdrawn from Western Lands Lease (Lot/DP)	Western Lands Lease affected by Withdrawal	Folio ID affected by Withdrawal	Area Withdrawn from Lease (ha)	Area of Lease following Withdrawal (ha)
3/1193988	2753	712/761920	1.825	5651
5/1193988	2753	712/761920	23.93	5627
7/1193988	2753	712/761920	15.49	5612
8/1193988	12668	719/761927	14.72	8888
9/1193988	2778	718/761926	43.17	8111
10/1193988	2932	717/761925	35.59	11693
12/1193988	2932	717/761925	29.68	11664
16/1193988	6288	3618/765970	68.10	7844
17/1193988	6289	3619/765971	40.58	4977
18/1193988	2988	1025/762252	40.73	7052
19/1193988	5317	3064/765289	29.23	6678
20/1193988	5318	3065/765290	39.05	4346
21/1193988	2164	368/761065	46.63	14797
23/1193988	2164	368/761065	29.04	14768
24/1193988	5645	3392/765679	49.36	9129
25/1193988	5887	3157/765362	91.04	17138
26/1193988	5481	3209/765414	31.31	7058
28/1193988	6288	3618/765970	4.065	7840
29/1193988	6290	3620/765972	30.80	7785
31/1193988	3002	6124/48783	34.40	9146
32/1193988	14314	6120/48783	34.66	6879
38/1193988	14316	6121/48783	46.36	6564
39/1193988	2164	368/761065	59.29	14709
40/1193988	2147	367/761070	12.20	8981
41/1193988	2147	367/761070	69.04	8912
43/1193988	1295	5872/768764	62.87	4038
44/1193988	1839	178/760771	30.06	5439

File No.: 14/00186

REVOCATION OF RESERVATION OF CROWN LAND

Pursuant to Section 90 of the *Crown Lands Act 1989*, the reservation of Crown specified in Column 1 of the Schedule hereunder is revoked to the extent specified opposite thereto in Column 2 of the Schedule.

The Hon Paul Toole, M.P.
Minister for Lands and Forestry

SCHEDULE

COLUMN 1	COLUMN 2
Reserve No.: 6 Purpose: Public Recreation Notified: 8 September 1862 Locality: Pooncarie Parish: Pooncaira County: Perry File No: WL99R0125	Those parts within Lot 2 DP1193988 for an area of 14.59 ha

File Ref: 14/00186

REVOCATION OF RESERVATION OF CROWN LAND

In pursuance of Section 61A of the *Commons Management Act 1989*, the setting aside of Crown land as a common as specified in Column 1 of the Schedule hereunder, is hereby revoked to the extent specified opposite thereto in Column 2 of the Schedule.

The Hon Paul Toole, M.P.
Minister for Lands and Forestry

SCHEDULE

COLUMN 1	COLUMN 2
Reserve No: 630058 Purpose: Temporary Common Notified: 12 February 1883 Locality: Pooncarie Parish: Pooncaira County: Perry File No: WL86R39	That part within Lot 2 DP1193988 for an area of 14.59 ha

File No. 14/00186

NOTIFICATION OF CLOSING OF A ROAD

In pursuance of the provisions of the *Roads Act 1993*, the road hereunder described is closed and the lands comprised therein cease to be public road and the rights of passage and access that previously existed in relation to the road is extinguished. Upon closing, title to the land, comprising the former public road, vests in the body specified in the Schedule hereunder.

The Hon Paul Toole, MP
Minister for Lands and Forestry

DESCRIPTION

*Parish – Grabben Gullen; County – King
Land District – Crookwell; LGA – Upper Lachlan*

Road Closed: Lot 1 DP 1235954

File No: 17/05889

SCHEDULE

On closing, the land within Lot 1 DP 1235954 remains vested in the State of New South Wales as Crown land.

NOTIFICATION OF CLOSING OF A ROAD

In pursuance of the provisions of the *Roads Act 1993*, the road hereunder described is closed and the lands comprised therein cease to be public road and the rights of passage and access that previously existed in relation to the road is extinguished. Upon closing, title to the land, comprising the former public road, vests in the body specified in the Schedule hereunder.

The Hon Paul Toole, MP
Minister for Lands and Forestry

DESCRIPTION

Parish – Skinner; County – Hardinge

Land District – Armidale; LGA – Armidale Regional

Road Closed: Lot 3 DP 1235523, Lot 2 DP 1236860

File No: 17/05882

SCHEDULE

On closing, the land within Lot 3 DP 1235523, Lot 2 DP 1236860 remains vested in the State of New South Wales as Crown land.

NOTIFICATION OF CLOSING OF A ROAD

In pursuance of the provisions of the *Roads Act 1993*, the road hereunder described is closed and the lands comprised therein cease to be public road and the rights of passage and access that previously existed in relation to the road is extinguished. Upon closing, title to the land, comprising the former public road, vests in the body specified in the Schedule hereunder.

The Hon Paul Toole, MP
Minister for Lands and Forestry

DESCRIPTION

Parish – Blakefield; County – Wallace

Land District – Cooma; LGA – Snowy Monaro Regional

Road Closed: Lot 2 DP 1236906

File No: 17/05273

SCHEDULE

On closing, the land within Lot 2 DP 1236906 remains vested in the State of New South Wales as Crown land.

NOTIFICATION OF CLOSING OF A ROAD

In pursuance of the provisions of the *Roads Act 1993*, the road hereunder described is closed and the lands comprised therein cease to be public road and the rights of passage and access that previously existed in relation to the road is extinguished. Upon closing, title to the land, comprising the former public road, vests in the body specified in the Schedule hereunder.

The Hon Paul Toole, MP
Minister for Lands and Forestry

DESCRIPTION

Parish – Severn; County – Gough

Land District – Glen Innes; LGA – Glen Innes Severn

Road Closed: Lot 1 DP 1236905

File No: 17/06583

SCHEDULE

On closing, the land within Lot 1 DP 1236905 remains vested in the State of New South Wales as Crown land.

NOTIFICATION OF CLOSING OF A ROAD

In pursuance of the provisions of the *Roads Act 1993*, the road hereunder described is closed and the lands comprised therein cease to be public road and the rights of passage and access that previously existed in relation to the road is extinguished. Upon closing, title to the land, comprising the former public road, vests in the body specified in the Schedule hereunder.

The Hon Paul Toole, MP
Minister for Lands and Forestry

DESCRIPTION

Parish – Eunanoreenya; County – Clarendon
Land District – Wagga Wagga; LGA – Wagga Wagga

Road Closed: Lot 1 & 2 DP 1238119

File No: 14/07824

SCHEDULE

On closing, the land within Lots 1 & 2 DP 1238119 remains vested in Wagga Wagga City Council as operational land for the purposes of the *Local Government Act 1993*.

Council Reference: Trahairs Road

NOTIFICATION OF CLOSING OF A ROAD

In pursuance of the provisions of the *Roads Act 1993*, the road hereunder described is closed and the lands comprised therein cease to be public road and the rights of passage and access that previously existed in relation to the road is extinguished. Upon closing, title to the land, comprising the former public road, vests in the body specified in the Schedule hereunder.

The Hon Paul Toole, MP
Minister for Lands and Forestry

DESCRIPTION

Parishes – Livingstone, Woomahrigong, Book Book; County – Wynyard
Land District – Wagga Wagga; LGA – Wagga Wagga

Road Closed: Lots 1-2 DP 1227295

File No: 16/01763

SCHEDULE

On closing, the land within Lots 1-2 DP 1227295 remains vested in the State of New South Wales as Crown land.

NOTIFICATION OF CLOSING OF A ROAD

In pursuance of the provisions of the *Roads Act 1993*, the road hereunder described is closed and the lands comprised therein cease to be public road and the rights of passage and access that previously existed in relation to the road is extinguished. Upon closing, title to the land, comprising the former public road, vests in the body specified in the Schedule hereunder.

The Hon Paul Toole, MP
Minister for Lands and Forestry

DESCRIPTION

Parish – Livingstone; County – Wynyard
Land District – Wagga Wagga; LGA – Wagga Wagga

Road Closed: Lot 3 DP 1227296

File No: 16/01764

SCHEDULE

On closing, the land within Lot 3 DP 1227296 remains vested in the State of New South Wales as Crown land.

NOTIFICATION OF CLOSING OF A ROAD

In pursuance of the provisions of the *Roads Act 1993*, the road hereunder described is closed and the lands comprised therein cease to be public road and the rights of passage and access that previously existed in relation to the road is extinguished. Upon closing, title to the land, comprising the former public road, vests in the body specified in the Schedule hereunder.

The Hon Paul Toole, MP
Minister for Lands and Forestry

DESCRIPTION

*Parishes – Mullengandra, Woomargama; County – Goulburn
Land District – Albury; LGA – Greater Hume Shire*

Road Closed: Lots 4-5 DP 1227297

File No: 16/01373

SCHEDULE

On closing, the land within Lots 4-5 DP 1227297 remains vested in the State of New South Wales as Crown land.

NOTIFICATION OF CLOSING OF A ROAD

In pursuance of the provisions of the *Roads Act 1993*, the road hereunder described is closed and the lands comprised therein cease to be public road and the rights of passage and access that previously existed in relation to the road is extinguished. Upon closing, title to the land, comprising the former public road, vests in the body specified in the Schedule hereunder.

The Hon Paul Toole, MP
Minister for Lands and Forestry

DESCRIPTION

*Parish – Shadforth; County – Bathurst
Land District – Orange; LGA – Orange*

Road Closed: Lot 1 DP 1233991

File No: 17/04829

SCHEDULE

On closing, the land within Lot 1 DP 1233991 remains vested in the State of New South Wales as Crown land.

REVOCATION OF RESERVATION OF CROWN LAND

Pursuant to section 90 of the *Crown Lands Act 1989*, the reservation of Crown land specified in Column 1 of the Schedule hereunder is revoked to the extent specified opposite thereto in Column 2 of the Schedule.

The Hon Paul Toole, MP
Minister for Lands and Forestry

Schedule

Column 1	Column 2
Land District: Forbes Local Government Area: Forbes Shire Council Locality: Forbes Reserve No. 85711 Public Purpose: future public requirements Notified: 25 March 1966 File Reference: 08/2388	The whole being Lot 1 DP 1127202 Parish Forbes County Ashburnham Area: about 1677 square metres

DEDICATION OF CROWN LAND AS PUBLIC ROAD

IT is hereby notified that in pursuance of Section 12 of the *Roads Act 1993*, the crown land particularised below is, from the date of publication of this notice, dedicated as public road. The public road hereby dedicated is declared not to be crown road within the meaning of the *Roads Act 1993*.

The Hon. Paul Toole M.P.
Minister for Lands and Forestry

Description

Parishes - Varies Counties - Varies

Land District - Varies

LGA - Cobar

Lot/DP	Lot/DP	Lot/DP	Lot/DP
1/1176566	17/1176566	37/1176566	56/1176566
2/1176566	18/1176566	38/1176566	57/1176566
3/1176566	19/1176566	39/1176566	58/1176566
4/1176566	20/1176566	40/1176566	59/1176566
5/1176566	21/1176566	41/1176566	60/1176566
6/1176566	22/1176566	43/1176566	63/1176566
7/1176566	23/1176566	44/1176566	64/1176566
8/1176566	24/1176566	45/1176566	65/1176566
9/1176566	26/1176566	47/1176566	67/1176566
10/1176566	29/1176566	48/1176566	68/1176566
11/1176566	30/1176566	49/1176566	69/1176566
12/1176566	31/1176566	50/1176566	70/1176566
13/1176566	33/1176566	51/1176566	71/1176566
14/1176566	34/1176566	52/1176566	72/1176566
15/1176566	35/1176566	53/1176566	73/1176566
16/1176566	36/1176566	54/1176566	

Note: Affected parts of Crown Reserves 937, 1055, 5927, 21587, 38562, 81797, and 81808 are hereby revoked by this dedication.

File No: 12/02241

NOTIFICATION OF CLOSING OF A ROAD

In pursuance of the provisions of the *Roads Act 1993*, the road hereunder described is closed and the lands comprised therein cease to be public road and the rights of passage and access that previously existed in relation to the road is extinguished. Upon closing, title to the land, comprising the former public road, vests in the body specified in the Schedule hereunder.

The Hon Paul Toole, MP
Minister for Lands and Forestry

DESCRIPTION

Parishes - Burra, Tumbarumba; County - Selwyn

Land District - Tumbarumba; LGA - Snowy Valleys

Road Closed: Lots 11-13 DP 1236210

File No: 17/00171

SCHEDULE

On closing, the land within Lots 11-13 DP 1236210 remains vested in the State of New South Wales as Crown land.

NOTIFICATION OF CLOSING OF A ROAD

In pursuance of the provisions of the *Roads Act 1993*, the road hereunder described is closed and the lands comprised therein cease to be public road and the rights of passage and access that previously existed in relation to the road is extinguished. Upon closing, title to the land, comprising the former public road, vests in the body specified in the Schedule hereunder.

The Hon Paul Toole, MP
Minister for Lands and Forestry

DESCRIPTION

*Parishes - Goolma, Yarrobil; County - Bligh
Land District - Wellington; LGA - Mid-Western Regional*

Road Closed: Lots 1-2 DP 1236083

File No: 17/04821

SCHEDULE

On closing, the land within Lots 1-2 DP 1236083 remains vested in the State of New South Wales as Crown land.

NOTIFICATION OF CLOSING OF A ROAD

In pursuance of the provisions of the *Roads Act 1993*, the road hereunder described is closed and the lands comprised therein cease to be public road and the rights of passage and access that previously existed in relation to the road is extinguished. Upon closing, title to the land, comprising the former public road, vests in the body specified in the Schedule hereunder.

The Hon Paul Toole, MP
Minister for Lands and Forestry

DESCRIPTION

*Parish - Craven; County - Selwyn
Land District - Tumbarumba; LGA - Snowy Valleys*

Road Closed: Lot 3 DP 1233066

File No: 17/00176

SCHEDULE

On closing, the land within Lot 3 DP 1233066 remains vested in the State of New South Wales as Crown land.

NOTIFICATION OF CLOSING OF A ROAD

In pursuance of the provisions of the *Roads Act 1993*, the road hereunder described is closed and the lands comprised therein cease to be public road and the rights of passage and access that previously existed in relation to the road is extinguished. Upon closing, title to the land, comprising the former public road, vests in the body specified in the Schedule hereunder.

The Hon Paul Toole, MP
Minister for Lands and Forestry

DESCRIPTION

*Parish - Rowan; County - Wynyard
Land District - Wagga Wagga; LGA - Wagga Wagga*

Road Closed: Lot 3 DP 1236150

File No: 17/06481

SCHEDULE

On closing, the land within Lot 3 DP 1236150 remains vested in the State of New South Wales as Crown land.

**NOTICE OF PURPOSE OTHER THAN THE DECLARED PURPOSE PURSUANT TO
SECTION 34A(2)(b) OF THE CROWN LANDS ACT 1989**

Pursuant to section 34A(2)(b) of the *Crown Lands Act 1989*, the Crown reserve(s) specified in Column 2 of the Schedule is to be used or occupied under a relevant interest granted for the purpose(s) specified in Column 1 of the Schedule where such use or occupation is other than the declared purpose of the reserve

The Hon Paul Toole, MP
Minister for Lands and Forestry

Schedule

Column 1	Column 2
Aged Care Facilities	Part Dedication No. 540040 being whole of Lot 1 DP 1230561 Public Purpose: public hall, public recreation Notified: 17 April 1953 File Reference: 15/03601

Schedule

Column 1	Column 2
Easements for Services	Part Dedication No. 540040 being part Lot 1 – 2 DP 1230561 Public Purpose: public hall, public recreation Notified: 17 April 1953 File Reference: 15/03601

APPOINTMENT OF TRUST BOARD MEMBERS

Pursuant to section 93 of the *Crown Lands Act 1989*, the persons whose names are specified in Column 1 of the Schedule hereunder are appointed, for the terms of office specified in that Column, as members of the trust board for the reserve trust specified opposite thereto in Column 2, which has been established and appointed as trustee of the reserve referred to opposite thereto in Column 3 of the Schedule.

The Hon Paul Toole, MP
Minister for Lands and Forestry

Schedule

Column 1	Column 2	Column 3
Leslie Albert Parsons (new member) For a term commencing the date of this notice and expiring 31 December 2021.	Inverell Pioneer Village Reserve Trust	Reserve No. 87505 Public Purpose: museum Notified: 14 November 1969 File Reference: AE81R91

**NOTICE OF PURPOSE OTHER THAN THE DECLARED PURPOSE PURSUANT TO
SECTION 34A(2)(b) OF THE CROWN LANDS ACT 1989**

Pursuant to section 34A(2)(b) of the *Crown Lands Act 1989*, the Crown reserve(s) specified in Column 2 of the Schedule is to be used or occupied under a relevant interest granted for the purpose(s) specified in Column 1 of the Schedule where such use or occupation is other than the declared purpose of the reserve

The Hon Paul Toole, MP
Minister for Lands and Forestry

Schedule

Column 1	Column 2
access	Reserve No. 73189 Public Purpose: public utility Notified: 20 May 1949 File Reference: 17/11625

Schedule

Column 1	Column 2
environmental protection	Reserve No. 85421 Public Purpose: preservation of fauna, preservation of native flora Notified: 13 August 1965 File Reference: 17/10292 Reserve No. 755455 Public Purpose: future public requirements Notified: 29 June 2007 File Reference: 17/11683

Schedule

Column 1	Column 2
dam grazing	Reserve No. 1013570 Public Purpose: future public requirements Notified: 8 June 2007 File Reference: 17/08127

Schedule

Column 1	Column 2
storage purposes building	Reserve No. 86199 Public Purpose: future public requirements Notified: 3 March 1967 File Reference: 16/04810

Schedule

Column 1	Column 2
dam	Reserve No. 753135 Public Purpose: future public requirements Notified: 29 June 2007 File Reference: 16/04810

Schedule

Column 1	Column 2
site investigation	Reserve No. 17075 Public Purpose: trigonometrical purposes Notified: 14 January 1893 File Reference: 17/10709 Reserve No. 77957 Public Purpose: generally Notified: 16 September 1955 File Reference: 17/10709

Column 1	Column 2
	<p>Reserve No. 80288 Public Purpose: generally Notified: 17 January 1958 File Reference: 17/10709</p> <p>Reserve No. 80835 Public Purpose: generally Notified: 11 July 1958 File Reference: 17/10709</p> <p>Reserve No. 93491 Public Purpose: future public requirements Notified: 5 September 1980 File Reference: 17/10709</p> <p>Reserve No. 93492 Public Purpose: future public requirements Notified: 5 September 1980 File Reference: 17/10709</p> <p>Reserve No. 93509 Public Purpose: future public requirements Notified: 5 September 1980 File Reference: 17/10709</p> <p>Reserve No. 93510 Public Purpose: future public requirements Notified: 5 September 1980 File Reference: 17/10709</p> <p>Reserve No. 93511 Public Purpose: future public requirements Notified: 5 September 1980 File Reference: 17/10709</p> <p>Reserve No. 750915 Public Purpose: future public requirements Notified: 29 June 2007 File Reference: 17/10709</p> <p>Reserve No. 750968 Public Purpose: future public requirements Notified: 29 June 2007 File Reference: 17/10709</p>

Schedule

Column 1	Column 2
<p>piles deck jetty berthing area</p>	<p>Reserve No. 1012130 Public Purpose: access and public requirements, tourism purposes and environmental and heritage conservation Notified: 11 August 2006 File Reference: 17/10747</p>

Schedule

Column 1	Column 2
aerodrome land management purposes	Reserve No. 100156 Public Purpose: future public requirements Notified: 18 November 1988 File Reference: 17/11502

Schedule

Column 1	Column 2
garden	Reserve No. 752035 Public Purpose: future public requirements Notified: 29 June 2007 File Reference: 17/07957

Schedule

Column 1	Column 2
road construction bridge construction	Reserve No. 10594 Public Purpose: camping Notified: 8 February 1890 File Reference: 17/09547 Reserve No. 10596 Public Purpose: camping Notified: 8 February 1890 File Reference: 17/09547 Reserve No. 86684 Public Purpose: travelling stock Notified: 11 April 1968 File Reference: 17/09547

Schedule

Column 1	Column 2
pipeline	Reserve No. 753223 Public Purpose: future public requirements Notified: 29 June 2007 File Reference: 17/06255 Reserve No. 72912 Public Purpose: future public requirements Notified: 26 November 1948 File Reference: 08/3100

Schedule

Column 1	Column 2
pump station	Reserve No. 71778 Public Purpose: future public requirements Notified: 21 December 1945 File Reference: 08/3100

Schedule

Column 1	Column 2
water supply	Reserve No. 78438 Public Purpose: public recreation Notified: 29 March 1956 File Reference: WL07H28-1

Notes: Existing reservations under the Crown Lands Act are not revoked.

APPOINTMENT OF TRUST BOARD MEMBERS

Pursuant to section 93 of the *Crown Lands Act 1989*, the persons whose names are specified in Column 1 of the Schedule hereunder are appointed, for the terms of office specified in that Column, as members of the trust board for the reserve trust specified opposite thereto in Column 2, which has been established and appointed as trustee of the reserve referred to opposite thereto in Column 3 of the Schedule.

The Hon Paul Toole, MP
Minister for Lands and Forestry

Schedule

Column 1	Column 2	Column 3
Matthew Peter Painter (new member) Daniel Watson Parker (new member) For a term commencing the date of this notice and expiring 30 October 2019.	Kyogle Showground And Public Recreation Trust	Dedication No. 540086 Public Purpose: public recreation, showground Notified: 24 November 1972 File Reference: 09/15552

ERRATUM

In the Government Gazette No 132 of 8 December 2017, Folio 7586, under the heading “Alteration of Corporate Name of Reserve Trust” Column 3 should read Woodburn River Bank Reserve Trust.

File Reference: GF03R28

The Hon Paul Toole, MP
Minister for Lands and Forestry

APPOINTMENT OF RESERVE TRUST AS TRUSTEE OF A RESERVE

Pursuant to section 92(1) of the *Crown Lands Act 1989*, the reserve trust specified in Column 1 of the Schedule hereunder is appointed as trustee of the reserve specified opposite thereto in Column 2 of the Schedule.

The Hon Paul Toole, MP
Minister for Lands and Forestry

Schedule

Column 1	Column 2
Woodburn River Bank Reserve Trust	Reserve No. 88216 Public Purpose: public recreation Notified: 30 April 1971 File Reference: GF87R31

APPOINTMENT OF TRUST BOARD MEMBERS

Pursuant to section 93 of the *Crown Lands Act 1989*, the persons whose names are specified in Column 1 of the Schedule hereunder are appointed, for the terms of office specified in that Column, as members of the trust board for the reserve trust specified opposite thereto in Column 2, which has been established and appointed as trustee of the reserve referred to opposite thereto in Column 3 of the Schedule.

The Hon Paul Toole, MP
Minister for Lands and Forestry

Schedule

Column 1	Column 2	Column 3
Brett Jessop (re-appointment) Joel Anderson (re-appointment) For a term commencing the date of this notice and expiring 13 December 2022.	Narira Park Trust	Reserve No. 83297 Public Purpose: public recreation Notified: 28 July 1961 Reserve No. 1011209 Public Purpose: community purposes Notified: 13 January 2006 File Reference: NA79R107

APPOINTMENT OF TRUST BOARD MEMBERS

Pursuant to section 93 of the *Crown Lands Act 1989*, the persons whose names are specified in Column 1 of the Schedule hereunder are appointed, for the terms of office specified in that Column, as members of the trust board for the reserve trust specified opposite thereto in Column 2, which has been established and appointed as trustee of the reserve referred to opposite thereto in Column 3 of the Schedule.

The Hon Paul Toole, MP
 Minister for Lands and Forestry

Schedule

Column 1	Column 2	Column 3
Jean Anne Kerle (re-appointment) John Richard Telfer (new member) Geoffrey Francis Denmead (re-appointment) Danielle Ranshaw (re-appointment) Michael Fleming (re-appointment) Glen Porter (re-appointment) Deborah Lee Munns (re-appointment) For a term commencing 01 January 2018 and expiring 31 December 2022.	Peel Native Flora & Fauna Reserve Trust	Reserve No. 91214 Public Purpose: promotion of the study and the preservation of native flora and fauna Notified: 4 August 1978 File Reference: OE90R17-002

Schedule

Column 1	Column 2	Column 3
Peter Hay (re-appointment) Christine Joy Reeves (re-appointment) Sharon Linda Chadwick (re-appointment) John Colin Chadwick (re-appointment) Rodney Gavin Lord (re-appointment) Stuart Allan Sim (re-appointment) For a term commencing 01 January 2018 and expiring 31 December 2022.	Running Stream Recreation Reserve Trust	Reserve No. 37372 Public Purpose: public recreation Notified: 12 March 1904 File Reference: OE80R121-004

Schedule

Column 1	Column 2	Column 3
Darryl Norman Henley (new member) Terence Eugene Reardon (re-appointment) Mark Ronald Helyar (new member) For a term commencing 22 December 2017 and expiring 21 December 2022.	West Milby Recreation Reserve Trust	Reserve No. 45614 Public Purpose: public hall Notified: 17 August 1910 Reserve No. 84196 Public Purpose: public recreation Notified: 15 February 1963 File Reference: OE81R73-003

APPOINTMENT OF TRUST BOARD MEMBERS

Pursuant to section 93 of the *Crown Lands Act 1989*, the persons whose names are specified in Column 1 of the Schedule hereunder are appointed, for the terms of office specified in that Column, as members of the trust board for the reserve trust specified opposite thereto in Column 2, which has been established and appointed as trustee of the reserve referred to opposite thereto in Column 3 of the Schedule.

The Hon Paul Toole, MP
Minister for Lands and Forestry

Schedule

Column 1	Column 2	Column 3
Gay Felicity Bigg (new member) James Moulton (re-appointment) Jeanette Elizabeth Csaszar (re-appointment) Wendy Gribble (new member) For a term commencing 20 February 2018 and expiring 19 February 2023.	Kundabung Public Recreation Reserve Trust	Reserve No. 63576 Public Purpose: public recreation Notified: 21 October 1932 File Reference: TE80R184-003

APPOINTMENT OF TRUST BOARD MEMBERS

Pursuant to section 93 of the *Crown Lands Act 1989*, the persons whose names are specified in Column 1 of the Schedule hereunder are appointed, for the terms of office specified in that Column, as members of the trust board for the reserve trust specified opposite thereto in Column 2, which has been established and appointed as trustee of the reserve referred to opposite thereto in Column 3 of the Schedule.

The Hon Paul Toole, MP
Minister for Lands and Forestry

Schedule

Column 1	Column 2	Column 3
John Stanley Carter (new member) William George McNamara (new member) For a term commencing the date of this notice and expiring 24 July 2019.	Kendall Community Centre Reserve Trust	Reserve No. 98013 Public Purpose: community purposes Notified: 6 December 1985 File Reference: TE85R23

Water Notices

HUNTER WATER ACT 1991

LAND ACQUISITION (JUST TERMS COMPENSATION) ACT 1991

HUNTER WATER CORPORATION

NOTICE OF COMPULSORY ACQUISITION OF INTEREST IN LAND (FREEHOLD) AT LOCHINVAR

Hunter Water Corporation declares, with the approval of His Excellency the Governor and the Executive Council that the interest in Land described in the Schedule below is acquired by compulsory process by in accordance with the provisions of the *Land Acquisition (Just Terms Compensation) Act 1991*, for water purposes under the *Hunter Water Act 1991*.

Dated at Sydney, the 18th day of December 2017.

Jim Bentley
Managing Director
Hunter Water Corporation

SCHEDULE

Parish – Gosforth; County – Northumberland

Land District – Lochinvar; LGA – Maitland

Land

Lot 1 DP 1230424

In so far as any Native Title rights and interests may exist over any of the Land described in the Schedule, the “non-extinguishment principle” as defined in section 238 of the *Native Title Act 1993* (Cth) applies to the acquisition.

Hunter Water Reference HW2009-1837

WATER MANAGEMENT ACT 2000

Order under section 134

SECTION 134 (2)

Exclusion of land from Jemalong Irrigation Limited’s Area of Operations

PURSUANT to section 134 (2) of the *Water Management Act 2000*, I, FRANK GAROFALOW, having delegated authority from the Minister for Regional Water do, by this Order, exclude the land listed in Schedule 1 from the area of operations of Jemalong Irrigation Limited.

This Order takes effect on the date that the Order is published in the NSW Government Gazette.

Signed at Parramatta this 3rd day of November 2017.

Frank Garofalow
Group Director Water Regulation
Crown Lands and Water Division
Signed for the Minister for Primary Industries
(by delegation)

SCHEDULE 1

Lot 20 DP1140289, Parish of Warroo, County of Gipps

Lot 1 DP665026, Parish of Warroo, County of Gipps

Lot 2 DP665027, Parish of Warroo, County of Gipps

Lot 5 DP132852, Parish of Warroo, County of Gipps

Lot 73 DP753127, Parish of Warroo, County of Gipps

Lot 74 DP753127, Parish of Warroo, County of Gipps

Lot 1 DP 186664, Parish of Warroo, County of Gipps

Lot 4 DP187215, Parish Warroo, County of Gipps

Other Government Notices

ANTI-DISCRIMINATION ACT 1977

EXEMPTION ORDER

Under the provisions of section 126 of the *Anti-Discrimination Act 1977*, an exemption is given from sections 25, 33 and 51 of the *Anti-Discrimination Act 1977* to **Hunter Medical Research Institute** to provide a medical research fellowship program for women only.

This exemption will remain in force for 10 years.

Dated this 19th day of December 2017.

Elizabeth Wing
Senior Manager, Operations
Delegate of the President
Anti-Discrimination Board of NSW

ANTI-DISCRIMINATION ACT 1977

EXEMPTION ORDER

Under the provisions of section 126 of the *Anti-Discrimination Act 1977*, an exemption is given from sections 8 and 51 of the *Anti-Discrimination Act 1977* to **Tamworth Regional Council** to designate and recruit a Trainee Environmental Health Officer position for Aboriginal and Torres Strait Islander persons only.

This exemption will remain in force for 6 years.

Dated this 19th day of December 2017

Elizabeth Wing
Senior Manager, Operations
Delegate of the President
Anti-Discrimination Board of NSW

ASSOCIATIONS INCORPORATION ACT 2009

Cancellation of incorporation pursuant to section 74

TAKE NOTICE that the incorporation of the following associations is cancelled by this notice pursuant to section 74 of the *Associations Incorporation Act 2009*.

AUSTRALIAN FLEET LESSORS ASSOCIATION INC	Y1525336
CAKE DECORATORS' GUILD OF N.S.W COWRA BRANCH INCORPORATED	Y2065535
DOUBLE BAY CHAMBER OF COMMERCE INCORPORATED	INC9889695
FUTUREWORLD – NATIONAL CENTRE FOR APPROPRIATE TECHNOLOGY INCORPORATED	Y1486314
LEADERSHIP DEVELOPMENT MINISTRIES INCORPORATED	INC9891322
THE MARQUETRY GUILD INC	Y1714039
NATIONAL SENIORS AUSTRALIA DRUMMOYNE BRANCH INCORPORATED	Y2131603
SAKYA TRINLEY LING INCORPORATED	INC9885655
WAGGA WAGGA BREAST CANCER GROUP INCORPORATED	INC9886250
THE WOLLONGONG GARDEN CLUB INC	Y1613929

Cancellation is effective as at the date of gazettal.

Dated this 20 December 2017.

Robyne Lunney
Delegate of the Commissioner
NSW Fair Trading

ASSOCIATIONS INCORPORATION ACT 2009

Cancellation of Registration pursuant to Section 76

TAKE NOTICE that the registration of the following associations is cancelled by this notice pursuant to section 76 of the *Associations Incorporation Act 2009*.

ACRES (ASIA-PACIFIC) INCORPORATED	INC9895376
AFRIAUSI ASSOCIATION INCORPORATED	INC9895342
AQUARIUS IN LOVEMORE INCORPORATED	INC1300458
ASHCROFT JUNIOR RUGBY LEAGUE FOOTBALL CLUB INCORPORATED	Y1770321
ASHFORD AMATEUR SWIMMING CLUB INCORPORATED	Y2018203
ASIA PACIFIC INDUSTRY & COMMERCE ASSOCIATION INCORPORATED	INC9886502
AUBURN TIGERS INC	INC9892592
AUSTRALIAN LIFESTYLE MEDICINE ASSOCIATION INCORPORATED	INC9889489
AUSTRALIAN TRICK RIDING ASSOCIATION INCORPORATED	INC9895345
AUSTRALIAN WALK OF FAME INCORPORATED	INC9884809
AUSTRALIAN-MAURITIAN NEW SOUTH WALES STATE FEDERATION (AMNSWSF) INCORPORATED	INC1601136
BAI FOCUS INCORPORATED	INC9889965
BARRABA AND DISTRICT CHAMBER OF COMMERCE INCORPORATED	INC9895350
BELMONT TINGIRA FOOTBALL CLUB INCORPORATED	INC9888706
CANYONLEIGH TRAIL RIDING CLUB INCORPORATED	INC9879032
CHINESE EAST-NORTH FRIENDSHIP ASSOCIATION INCORPORATED	INC9895394
CHRISTIAN HAPPY LIFE INCORPORATED	INC9895386
CUMMBEYAN ABORIGINAL HEALTH SERVICE INCORPORATED	INC9892643
DHEO-KA INCORPORATED	INC9895395
DOM'S PENRITH OLD BOY'S ASSOCIATION INCORPORATED	INC1500135
DOUBLE BRIDGE FARM INCORPORATED	INC9895363
DUBBO EDUCATION FUND INCORPORATED	INC9893883
EDEN CREEK ENDURANCE CLUB INCORPORATED	INC9885988
ELEARNING NETWORK OF AUSTRALASIA (ELNET) INCORPORATED	INC9881709
EMMANUEL WORSHIP CENTRE INCORPORATED	INC9886431
FAR NORTH COAST MYALGIC ENCEPHALOMYELITIS/CHRONIC FATIGUE SYNDROME (ME/CFS) ASSOCIATION INCORPORATED	INC9895406
GUNNEDAH SOUTH PUBLIC SCHOOL P & C ASSOCIATION INCORPORATED	INC3410600
HEADS UP (NSW) INCORPORATED	INC9895392
INDONESIA CULTURAL PROMOTION INCORPORATED	INC9895399
INSTITUTE OF CONTEMPORARY ART NEWTOWN INCORPORATED	INC9895371
INTERNATIONAL ASSOCIATION OF CONSCIOUSNESS INCORPORATED	INC9882113
LARGS FOOTBALL CLUB INC	INC9883257

LIONS CLUB OF TAMWORTH NEXT GENERATION INCORPORATED	INC9895396
LIONS CLUB OF WOOLLAHRA-VAUCLUSE INC.	Y0844714
LOW FOUR 4X4 CLUB INCORPORATED	INC9895365
MANLY WARRINGAH WINTER BASEBALL ASSOCIATION INC	Y1273925
MOREE PLAINS CAMPDRAFT CLUB INCORPORATED	INC9895364
NGA WAHINE MAURI ORA INCORPORATED	INC9895383
NINGENA SAM HOOKEY R.L.F.C INCORPORATED	INC9895410
NORTHLAKES NETBALL CLUB INCORPORATED	Y1910923
ONE IN FIVE CREATIVE ARTS ASSOCIATION INC	INC9895401
ROBERTSON VILLAGE MUSIC SOCIETY INCORPORATED	INC9888025
ROTARY CLUB OF MIRANDA INC	Y1307005
SOUTH WEST STRIKERS HOCKEY CLUB INCORPORATED	INC9882203
SOUTHERN DISTRICTS FUTSAL ASSOCIATION INCORPORATED	INC9895405
ST JOHN, IMAR CHARITABLE ASSOCIATION INCORPORATED	INC9895356
STRELITZIA MUSIC INCORPORATED	INC9895391
SYDNEY MALAYALI RADIO 2000 INC	INC9896567
THE AUSTRALIAN-MAURITIAN NATIONAL FEDERATION INCORPORATED	INC1601084
THE CANOBOLAS PARKLAND PROJECT INCORPORATED	INC9895384
THE MOOREBANK RESIDENTS ACTION GROUP INCORPORATED	INC9896029
THREDBO SNOW SPORTS INSTRUCTORS ASSOCIATION INCORPORATED	INC9895375
TUMBARUMBA MOTORCYCLE SPORTS CLUB INCORPORATED	INC9887370
VIETNAMESE AUSTRALIAN SOCCER ASSOCIATION INCORPORATED	INC9895359
WALCHA UNITED FOOTBALL CLUB INCORPORATED	Y1401606
WARILLA HOTEL SOCCER CLUB INCORPORATED	INC9895462
WOLLONGBAR ALSTONVILLE JUNIOR AFL CLUB INCORPORATED	INC9890770
WOMAN IN FOOTBALL SUPPORT INCORPORATED	INC9895397
WOMEN IN THE WAVES (SOUTH) INCORPORATED	INC9883285
WORLD LEBANESE CULTURAL UNION OF AUSTRALIA INCORPORATED	INC9895351

Cancellation is effective as at the date of gazettal.

Dated this 20th day of December 2017.

Christine Gowland
 Delegate of the Commissioner
 NSW Fair Trading

CHARITABLE TRUSTS ACT 1993

ERRATUM

The following Order which was published in the New South Wales Government Gazette of 15 December 2017 on pages 7736 and 7737 was published with errors. The Order is republished in full correcting those errors. The gazettal date remains 15 December 2017.

CHARITABLE TRUSTS ACT 1993

ORDER UNDER SECTION 12

CY PRÈS SCHEME RELATING TO THE ESTATE OF THE LATE EMILY CLAUGHTON

Section 9(1) of the *Charitable Trusts Act 1993* permits the application of property *cy près* where the spirit of the original trust can no longer be implemented.

The trustees of the estate of the late Emily Cloughton have applied to the Attorney General seeking that he establish a scheme under section 12 of the *Charitable Trusts Act 1993*.

Sub clauses 5(d) and 5(e) in the Will of Ms Cloughton bequeathed one thousand pounds upon trust to invest and pay the income thereof to the Ladies Benevolent Society at Hay and the Ladies Benevolent Society at Echuca, for the purposes of each respective Society. The value of the two trusts amounted to a corpus of \$4000 in total which earned a net income of \$55.70 for the financial year ended 30 June 2016.

The Will, in clause 6, bequeathed the residue of the estate to be held on trust with the residue to be applied:

'towards the maintenance and support of any Hospital or Benevolent Institutions now or hereafter provided and maintained by the Church of England or Presbyterian Church in the States of New South Wales and Victoria as my Trustees shall think fit'.

On 20 May 1930, the Supreme Court, in proceedings 8440/1930, established a scheme in relation to clause 6 on the grounds that it was expedient and necessary for the administration of the trust 'that the ambit of the powers affecting the distribution of the income of the said Residuary Trust Fund conferred by the said Will on the Trustees of the said trust should be defined'. The balance of the corpus of the residue fund for the financial year ended 30 June 2016 was \$243,021.80 and the total net income was \$24,185.51.

As delegate of the Attorney General, I have formed a view that all three bequests in the Will are trusts for a charitable purpose. It is apparent that a *cy près* scheme is required for the gifts made to the Ladies' Benevolent Societies at Hay (which is no longer in existence) and Echuca (which has changed its name, legal status and purposes). The funds that were applied to the Ladies' Benevolent society at Hay were applied, when it ceased to function, to a new committee which was formed in 2009, known as the Hay Community Fund. This Fund was wound up in approximately 2013, and all the funds transferred to the organisation 'Can Assist', which is an organisation which raises funds to assist persons in the Hay community with cancer.

The Echuca Ladies' Benevolent Society is now the Echuca Benevolent Society Incorporated and operates as the Echuca Community for the Aged ('ECA'). Its purposes are more focussed on aged care than were those of the original Society. However, the ECA's purposes are still charitable purposes, namely, assistance to the needy.

In respect of the gift of the residue of the estate, it is no longer possible to apply the fund for the purposes set out in the Court ordered scheme (proceedings 8440/1930) because the institutions that were previously entitled to receive the funds have gradually ceased to provide their services or facilities exclusively for ex-servicemen and women, necessitating an application of the fund *cy près*. The two nominated bodies for the application of the funds are the Anglican Retirement Villages Diocese of Sydney Foundation for Aged Care and the Presbyterian Church (New South Wales) Property Trust, for the purpose of maintenance and support of aged care programs. These organisations have a stronger aged care focus than was present in the original bequest purpose, but they are as close as possible to the original purposes and therefore are appropriate organisations for the *cy près* application of the funds.

I consider that the original charitable purpose has failed and that this is an appropriate matter in which the Attorney General should approve a *cy près* scheme under section 12(1)(a) of the *Charitable Trusts Act 1993* in respect of the three bequests in the Will of Emily Cloughton. The scheme would apply, *cy près*, the corpus the subject of the following trusts in the Will:

- (a) In relation to the gift in cl. 5(e) of the Will, \$2,000 to be applied to the 'Echuca Benevolent Society Incorporated' ABN 20 851 915 039 (trading as 'Echuca Community for the Aged'); and

- (b) In relation to the gift in cl. 5(d) of the Will, \$2,000 to be applied to the Hay Branch of Can Assist (Cancer Patients Assistance Society of New South Wales) ABN 76 000 412 715 for the benefit of residents of the town of Hay in New South Wales; and
- (c) In relation to the gift in cl. 6 of the Will, constituting the residue of the estate, to be applied in equal portions to:
 - (i) The Anglican Retirement Villages Diocese of Sydney Foundation for Aged Care ABN 24 086 334 058 for the purpose of maintenance and support of that Foundation's Aged Care programs; and
 - (ii) The Presbyterian Church (New South Wales) Property Trust for the purpose of supporting and maintaining benevolent institutions run by Presbyterian Aged Care ABN 70282579844.

The above scheme was advertised by way of Notice in the New South Wales Government Gazette on 13 October 2017. As no representations have been received within one month following that publication, I now hereby Order the establishment of the scheme.

This Order will take effect 21 days after its publication in the Government Gazette, in accordance with section 16(2) of the *Charitable Trusts Act 1993*.

Date of Order: 7 December 2017

MG SEXTON, SC
Solicitor General (Under delegation from the Attorney General)

CRIMES (DOMESTIC AND PERSONAL VIOLENCE) ACT 2007

ORDER

Nomination of Local Coordination Points

In pursuance of the provisions of sections 980(4) of the *Crimes (Domestic and Personal Violence) Act 2007*, the support agencies and non-government support services in Schedule 1 are nominated as Local Coordination Points for the purposes of Part 13A of that Act. This order has effect from the 1 January 2018

Mark Speakman, SC, M.P.
Attorney General
18/12/17

SCHEDULE 1

1. Blue Mountains Women's Domestic Violence Court Advocacy Service
2. Burwood Women's Domestic Violence Court Advocacy Service
3. Castlereagh Women's Domestic Violence Court Advocacy Service
1. Central Coast Women's Domestic Violence Court Advocacy Service
4. Central West Women's Domestic Violence Court Advocacy Service
5. Far South Coast Women's Domestic Violence Court Advocacy Service
6. Far West Women's Domestic Violence Court Advocacy Service
7. Hunter Women's Domestic Violence Court Advocacy Service
8. Hunter Valley Women's Domestic Violence Court Advocacy Service
9. Illawarra Women's Domestic Violence Court Advocacy Service
10. Macarthur Women's Domestic Violence Court Advocacy Service
11. Macquarie Women's Domestic Violence Court Advocacy Service
12. Mid-North Coast Women's Domestic Violence Court Advocacy Service
13. New England Women's Domestic Violence Court Advocacy Service
14. North Coast Women's Domestic Violence Court Advocacy Service
15. North West Women's Domestic Violence Court Advocacy Service
16. North West Sydney Women's Domestic Violence Court Advocacy Service
17. Northern Rivers Women's Domestic Violence Court Advocacy Service
18. Northern Sydney Women's Domestic Violence Court Advocacy Service
19. Riverina Women's Domestic Violence Court Advocacy Service
20. South Coast Women's Domestic Violence Court Advocacy Service

21. South Eastern Women's Domestic Violence Court Advocacy Service
 22. South West Sydney Women's Domestic Violence Court Advocacy Service
 23. Southern Women's Domestic Violence Court Advocacy Service
 24. Southern Sydney Women's Domestic Violence Court Advocacy Service
 25. Sydney Women's Domestic Violence Court Advocacy Service
 26. Wagga Wagga Women's Domestic Violence Court Advocacy Service
 27. Western Women's Domestic Violence Court Advocacy Service
 28. Western Sydney Women's Domestic Violence Court Advocacy Service
 29. Victims Services in the NSW Department of Justice
 30. Relationships Australia NSW
 31. The Family Centre
 32. Catholic Care Sydney
 33. Relationships Australia Canberra
 34. Interrelate
-

GEOGRAPHICAL NAMES ACT 1966

Notice of Proposal to Amend Suburb Boundaries in the Camden Local Government Area

PURSUANT to the provisions of section 8 of the *Geographical Names Act 1966*, the Geographical Names Board hereby notifies that it proposes to amend the suburb boundaries of Narellan and Elderslie in the Camden Local Government Area as shown on map GNB3568-5-A.

Copies of map GNB3568-5-A showing the proposed suburb boundary amendments will be on display at the Camden Library located at 40 John Street, Camden and the Narellan Library at the corner of Queen & Elyard Streets, Narellan.

The maps will be on display from Tuesday 19 December 2017 until Friday 26 January 2018.

A copy of map GNB3568-5-A will also be on display at the office of the Geographical Names Board, Spatial Services, 346 Panorama Avenue, Bathurst NSW 2795 during the above dates.

The proposal can be viewed and submissions lodged on the Geographical Names Board website at www.gnb.nsw.gov.au from 19 December 2017 until 26 January 2018. Alternatively, email submissions may be lodged with the Secretary, Geographical Names Board, at ss-gnb@finance.nsw.gov.au or written submissions mailed to 346 Panorama Ave, Bathurst, NSW 2795.

In accordance with section 9 of the *Geographical Names Act 1966* all submissions lodged may be subject to a Government Information (Public Access) application and may be viewed by a third party to assist the Board in considering this proposal.

Narelle Underwood
Chair
Geographical Names Board
PO Box 143
BATHURST NSW 2795

GEOGRAPHICAL NAMES ACT 1966

Notice of Proposal to Amend Locality Boundaries in the Lismore Local Government Area

PURSUANT to the provisions of Section 8 of the *Geographical Names Act 1966*, the Geographical Names Board hereby notifies that it proposes to amend the locality boundaries of Coffee Camp and Jiggi in the Lismore Local Government Area as shown on map GNB3628-2-A.

Copies of map GNB3628-2-A will be placed on display at the Lismore City Council office at 43 Oliver Avenue, Goonellabah from Wednesday 20 December 2017 to Wednesday 24 January 2018.

A copy of map GNB3628-2-A will also be on display at the office of the Geographical Names Board, Spatial Services, 346 Panorama Avenue, Bathurst NSW 2795 during the above dates.

Details of this proposal may also be viewed and submissions lodged on the Geographical Names Board's website at www.gnb.nsw.gov.au. Alternatively, email submissions may be lodged with the Secretary, Geographical Names Board, at ss-gnb@finance.nsw.gov.au or written submissions mailed to 346 Panorama Ave, Bathurst, NSW 2795.

In accordance with Section 9 of the *Geographical Names Act 1966*, all submissions lodged may be subject to a Government Information (Public Access) application and may be viewed by a third party to assist the Board in considering this proposal.

NARELLE UNDERWOOD
Chair
Geographical Names Board
PO Box 143
BATHURST NSW 2795

LAND TAX MANAGEMENT ACT 1956

Land Tax (including Surcharge Land Tax) Returns for 2018 Tax Year

1. This Order is made under section 12(1) of the *Land Tax Management Act 1956* and section 37 of the *Taxation Administration Act 1996*. The purpose of this Order is to advise persons who own land in New South Wales if and when they are required to lodge an initial return or a variation return in relation to the 2018 land tax year or an earlier tax year.

Persons Who Must Lodge an Initial Return

2. The requirement to lodge an initial land tax return in 2018, as specified in this Order, applies to certain "persons" who are "owners" of land in New South Wales at midnight on 31 December 2017 (or any previous year if paragraph 6 applies). The reference to an "owner" includes a reference to a person who is an owner of land or is deemed to be an owner for land tax purposes by the *Land Tax Management Act 1956*. A "person" includes a company, a trustee, a beneficiary of a trust and a natural person.
3. Persons who own land in New South Wales at midnight on 31 December 2017 which is not exempt from land tax must lodge an initial return unless they were assessed and received a land tax notice of assessment for the 2017 land tax year.
4. Persons who are foreign persons for the purposes of surcharge land tax **and** who own residential land in New South Wales at midnight on 31 December 2017 which is not exempt from surcharge land tax must lodge an initial return.
5. Persons who have received a land tax notice of assessment for any land tax year prior to 2018 showing nil tax payable and who have subsequently acquired additional land or an additional interest in land and are the owners of land at midnight 31 December 2017 which is not exempt from land tax must lodge an initial return.
6. Persons who are liable to be assessed for land tax for any tax year prior to 2018 and have not previously lodged a return for that tax year, or have not received a land tax notice of assessment for that tax year must also lodge an initial return.
7. Persons who own land that has previously been exempt from land tax in any tax year prior to 2018 but is not exempt for the 2018 tax year must lodge an initial return.
8. Where land is subject to a trust, and the trustee has not previously lodged a land tax return, the trustee must lodge an initial return on behalf of the trust. If the trustee fails to lodge a return, or fails to provide the information specified on the form about the beneficiaries of the trust, the trust may be assessed as if it were a special trust.
9. A Land Tax Registration Form is an initial return for the purposes of section 12.

Due Date for Lodgement of Initial Returns

10. Any person who is required by this Order to lodge an initial return must do so by 31 March 2018.
11. Penalty tax and interest may be imposed under the *Land Tax Management Act 1956* and the *Taxation Administration Act 1996* for failing to lodge a return by the due date.

Persons Who Must Lodge a Variation Return

12. A variation return is required to be lodged by a person who receives an incorrect notice of assessment of land tax. Errors on the notice which may result in an incorrect notice of assessment of land tax may occur in the following circumstances:
- (a) a foreign person who has not been correctly assessed for surcharge land tax;
 - (b) details of land owned by the person as shown on the notice are incorrect (including but not limited to inclusion of land disposed of prior to midnight on 31 December 2017; land acquired prior to midnight on 31 December 2017 that has not been included in the assessment; the percentage interest in land is incorrect for land that is jointly owned; land shown in an assessment is owned by the person in the capacity of trustee but is not shown as such; or an incorrect property description is shown);
 - (c) exempt land has been incorrectly assessed as liable for land tax;
 - (d) liable land has been incorrectly assessed as exempt from land tax;
 - (e) an exemption was previously granted subject to conditions which have not been fulfilled;
 - (f) the calculation of tax is incorrect (being either too high or too low);
 - (g) a special trust has been incorrectly assessed as if it were a fixed trust;
 - (h) a fixed trust has been incorrectly assessed as if it were a special trust;
 - (i) the beneficiaries of a family unit trust have changed since 31 December 2005;
 - (j) the beneficial interests of the beneficiaries of a family unit trust have changed since 31 December 2005;
 - (k) additional land has been acquired by a family unit trust, and the total liable land owned by the trust has a taxable value of more than \$1 million for the tax year during which the land was acquired;
 - (l) a group constituted under section 29 of the *Land Tax Management Act 1956* does not have a member classified as a concessional company;
 - (m) a group constituted under section 29 of the *Land Tax Management Act 1956* has more than one member classified and separately assessed as a concessional company (note that two or more companies can be correctly classified as joint concessional companies and jointly assessed as such);
 - (n) an error occurred in the calculation of the average value of a parcel of land.
13. A variation return is required to be lodged if the trustee of a trust that has an interest in land has not previously advised the Chief Commissioner of the existence of the trust, or if the trust has been incorrectly assessed as either a fixed trust when it is a special trust or as a special trust when it is a fixed trust.
14. A variation return disclosing details of the beneficiaries must be lodged by a trustee of a trust, other than a special trust, if the trustee has not previously advised the Chief Commissioner of the beneficiaries of the trust or the beneficial owners of land owned by the trust. If a trustee fails to comply with this requirement, the Chief Commissioner may classify the trust as a special trust.
15. A variation return must be lodged by a trustee of a trust disclosing if any beneficiaries or potential beneficiaries are foreign persons, if the trustee has not previously advised the Chief Commissioner that the trust has foreign persons as beneficiaries.

Due Date for Lodgement of Variation Returns

16. A variation return is required to be lodged by the first instalment date shown on the notice of assessment. If the notice of assessment shows that no tax is payable, the due date for lodgement of a variation return is 40 days after the "Issue Date" shown on the notice.
17. Penalty tax and interest may be imposed under the *Land Tax Management Act 1956* and the *Taxation Administration Act 1996* for failing to lodge a return by the due date.

Information about Surcharge Land Tax

18. For the purposes of surcharge land tax, a foreign person includes:
- (a) an individual not ordinarily resident in Australia; or
 - (b) a corporation in which an individual not ordinarily resident in Australia, a foreign corporation or a foreign government holds a substantial interest; or
 - (c) a corporation in which 2 or more persons, each of whom is an individual not ordinarily resident in Australia, a foreign corporation or a foreign government, hold an aggregate substantial interest; or
 - (d) the trustee of a trust in which an individual not ordinarily resident in Australia, a foreign corporation or a foreign government holds a substantial interest; or

- (e) the trustee of a trust in which 2 or more persons, each of whom is an individual not ordinarily resident in Australia, a foreign corporation or a foreign government, hold an aggregate substantial interest; or
- (f) a foreign government; or
- (g) a general partner of a limited partnership where:
 - i. an individual not ordinarily resident in Australia, a foreign corporation or a foreign government holds at least 20% in the limited partnership, or
 - ii. two or more persons each of whom is an individual not ordinarily resident in Australia, a foreign corporation or a foreign government, hold an aggregate interest of at least 40% in the limited partnership.

Australian Citizens are not foreign persons, irrespective of where they reside.

19. For the purposes of surcharge land tax, residential land means any of the following and does not include any land used for primary production as defined in section 10AA of the *Land Tax Management Act*:
- (a) a parcel of land on which there are one or more dwellings, or a parcel of land on which there is a building under construction that, when completed, will constitute one or more dwellings, or
 - (b) a strata lot, if it is lawfully occupied as a separate dwelling, or suitable for lawful occupation as a separate dwelling, or
 - (c) a utility lot if its use is restricted to the owner or occupier of a strata lot described in paragraph 19(b), or
 - (d) a land use entitlement, if it entitles the holder to occupy a building, or part of a building, as a separate dwelling, or
 - (e) a parcel of vacant land that is zoned or otherwise designated for use for residential or principally for residential purposes.
20. A foreign person who jointly owns residential land may be liable for surcharge land tax on the person's proportionate interest in the jointly owned residential land.

How to Lodge a Return

21. A person, including an agent or trustee will satisfy the obligation to lodge an initial return, a variation return or a surcharge return by lodging a return form electronically via the Revenue NSW website at www.revenue.nsw.gov.au.
22. Relevant information may also be provided by telephone or by email. Contact details and business hours are published on the Revenue NSW website.

Other Matters

23. In some cases lodging by webform will not be possible and a written return form may still be required.
24. Note also that under section 12(2) of the *Land Tax Management Act 1956*, the Chief Commissioner may require any person to lodge a return or a further return in circumstances other than those described in this Notice.
25. A requirement to lodge a return specified in this notice does not affect a requirement to lodge a return by an earlier date specified by the Chief Commissioner under section 12(2) of the Act or an earlier date specified in any previous Order made under section 12(1).

Land tax and surcharge land tax information is available on the Revenue NSW website at www.revenue.nsw.gov.au.

Stephen R Brady
Chief Commissioner of State Revenue
20 December 2017

POISONS AND THERAPEUTIC GOODS REGULATION 2008

ORDER

Withdrawal of Drug Authority

In accordance with the provisions of clause 175(1) of the *Poisons and Therapeutic Goods Regulation 2008* an Order has been made on **Dr Karl Max KOLLER (MED0001044449)**, of Taree NSW 2430, prohibiting him until further notice, as a medical practitioner, from supplying or having possession of drugs of addiction as authorised by clause 101 of the Regulation and issuing a prescription for a drug of addiction as authorised by clause 77 of the Regulation.

This Order is to take effect on and from 8 November 2017.

Dated at Sydney, 6 November 2017

ELIZABETH KOFF
Secretary
NSW Health

WORK HEALTH AND SAFETY REGULATION 2017

Exemption Order No. 015/17

I, Peter Dunphy, Executive Director, SafeWork NSW, pursuant to clause 684 of the *Work Health and Safety Regulation 2017* (the Regulation) hereby grant the following exemption:

Dated this 19th day of December 2017

Peter Dunphy
Executive Director SafeWork NSW

1. Name of Exemption

This Exemption Order is the *Work Health and Safety Regulation 2017 Exemption Order No. 015/17*.

2. Commencement

This Exemption Order commences on 1 January 2018 and has effect until 31 December 2022.

3. Exemption

The Applicant for this Exemption Order is the University of New South Wales.

This Exemption Order applies to diving activities undertaken by students and volunteer divers, who are authorised to undertake those diving activities by the institutions listed below as part of honours or post graduate research or education in marine sciences.

- a. University of New South Wales
- b. University of Technology, Sydney
- c. Sydney Institute of Marine Science
- d. University of Sydney
- e. University of Newcastle
- f. University of Wollongong
- g. Macquarie University
- h. University of Western Sydney
- i. Southern Cross University
- j. Australian Catholic University

Those persons are exempt from Clause 171 of the Regulation, subject to the conditions in the Schedule to this Exemption Order.

4. Definitions

For the purposes of this Exemption:

General diving work means general diving work as defined in clause 5 of the Regulation

Volunteer diver means a person who is acting on a voluntary basis and undertakes diving activities in order to assist Students, workers or others in the conduct of their research or education.

Student means an enrolled honours or post graduate university student undertaking research or education in marine sciences.

5. Schedule

This Exemption is subject to the following conditions:

- a) The Person Conducting a Business or Undertaking (PCBU) being the institutions listed in clause 3 above, must only apply this exemption to Students who undertake diving work in pursuit of formal honours or post graduate research and education coursework and volunteer divers involved in volunteer dive support with the institution.
 - b) All persons described in (a) must comply with AS/NZS 2299.2:2002 Occupational Diving Operations Part 2: Scientific Diving and in particular, the qualifications and practices prescribed in Appendix A4 generally and A4.3 Restrictions (Restricted Scientific Diver) at all times.
 - c) Persons described in (a) as volunteer divers must not be responsible for the management or supervision of Students, workers or others on behalf of the persons conducting a business or undertaking at any time.
 - d) Nothing in this Exemption affects any other applicable requirement imposed by law in relation to the matters relating to this Exemption.
-

WORK HEALTH AND SAFETY REGULATION 2017

(Clause 58(2))

Exemption Order No. 016/17

I, Peter DUNPHY, Executive Director, SafeWork NSW, pursuant to Clause 684 of the *Work Health and Safety Regulation 2017* grant the following exemption:

Dated this 19th day of December 2017.

Peter DUNPHY
Executive Director SafeWork NSW

Work Health and Safety Regulation 2017 Exemption No. 016/17

1. Name of Exemption

This Exemption Order is the *Work Health and Safety Regulation 2017, Exemption Order No. 016/17*.

2. Commencement

This Exemption Order commences on 1 January 2018 and has effect until 31 December 2018.

3. Exemption

This Exemption Order is made by SafeWork NSW on its own initiative.

This Exemption Order applies to persons conducting a business or undertaking who require a worker to frequently use personal protective equipment as a control measure to protect workers from the risk of hearing loss associated with noise that exceeds the 'exposure standard for noise'.

Those persons are exempt from Clause 58(2) of the Regulation, subject to the condition in the Schedule to this Exemption Order.

4. Definitions

For the purposes of this Exemption:

Regulation means the *Work Health and Safety Regulation 2017*.

Exposure standard for noise means $L_{Aeq,8h}$ of 85 dB(A) or $L_{c,peak}$ of 140 dB(C) where $L_{Aeq,8h}$ means the eight hour equivalent continuous A-weighted sound pressure level in decibels (dB(A)) referenced to 20 micropascals, determined in accordance with AS/NZS 1269.1:2005 and $L_{c,peak}$ means the C-weighted peak sound pressure level in decibels (dB(C)) referenced to 20 micropascals, determined in accordance with AS/NZS 1269.1:2005.

SCHEDULE

This Exemption is subject to the following condition:

1. Nothing in this Exemption affects any other applicable requirement imposed by law on a person conducting a business or undertaking in relation to matters relating to this Exemption, including the monitoring of workers and conditions at the workplace under Section 19(3)(g) *Work Health and Safety Act 2011*.

PROFESSIONAL STANDARDS ACT 1994

Notification Pursuant to Section 13

Pursuant to section 13 of the *Professional Standards Act 1994*, I authorise the publication of The CPA Australia Ltd Professional Standards (Accountants) Scheme.

MATT KEAN, MP
Minister for Innovation and Better Regulation

THE CPA AUSTRALIA LTD PROFESSIONAL STANDARDS (ACCOUNTANTS) SCHEME

Professional Standards Act 1994 (NSW)

PREAMBLE

- A. CPA Australia Ltd ("**CPA Australia**") is a national occupational association.
- B. CPA Australia has made an application to the Professional Standards Council, appointed under the *Professional Standards Act 1994 (NSW)* ("**the Act**") for approval of a scheme under the Act.
- C. The Scheme is prepared by CPA Australia for the purposes of limiting Occupational Liability to the extent to which such liability may be limited under the Act.
- D. The Scheme propounded by CPA Australia is to apply to all participating members referred to in clause 2 of the Scheme and as otherwise stated in that clause.
- E. CPA Australia has furnished the Council with a detailed list of the risk management strategies intended to be implemented in respect of its members and the means by which those strategies are intended to be implemented.
- F. All participating members referred to in clause 2 of the Scheme are subject to disciplinary measures under the Constitution and By-Laws of CPA Australia and are also subject to the professional indemnity insurance requirements under the By-Laws of CPA Australia.
- G. The Scheme is intended to remain in force for a period of two (2) years from the date of commencement in each jurisdiction for which it is in force unless it is revoked, extended or ceases in accordance with section 32 of the Act.
- H. This Scheme is not intended to apply to holders of an Australian Financial Services Licence under Chapter 7 of the Corporations Act 2001 (Cth) other than those who hold a Limited Licence.

THE CPA AUSTRALIA LTD PROFESSIONAL STANDARDS (ACCOUNTANTS) SCHEME

1. Occupational Association

- 1.1. The CPA Australia Ltd Professional Standards (Accountants) Scheme (the "**Scheme**") is a scheme under "the Act" of CPA Australia, Level 20, 28 Freshwater Place, Southbank Victoria 3006.
- 1.2. Definitions of terms used in the Scheme appear in the Scheme, including in Part 4.

2. Persons to Whom the Scheme Applies

- 2.1. This Scheme applies to:

- (a) all CPA Australia members who hold a current Public Practice Certificate issued by CPA Australia other than:
- (i) such members who also hold an Australian Financial Services Licence granted in accordance with section 913B of the Corporations Act 2001 (Cth), not being a Limited Licence; and
 - (ii) Representatives of licensees under section 913B of the Corporations Act 2001 (Cth), not being a Limited Licence;

And

- (b) all persons to whom the Scheme applies, by virtue of the Act¹ and the corresponding provisions of the Acts² of other jurisdictions in which the Scheme applies.

Each such participating member and person is referred to in the Scheme as a "participant".

- 2.2 No participant to whom the Scheme applies may choose not to be subject to the Scheme, however CPA Australia may, on written application by a participant referred to in clause 2.1(a), exempt the participant from the Scheme if CPA Australia is satisfied that he or

¹ Sections 18 and 19 of the Act provide that if the Scheme applies to a body corporate, the Scheme also applies to each officer of the body corporate and if the Scheme applies to a person, the Scheme also applies to each partner of a person, and if the Scheme applies to a person, the Scheme also applies to each employee of that person, provided that if such officer of the corporation or partner of the person or employee of the person is entitled to be a member of the same occupational association, such officer, partner or employee is a member of the occupational association. Section 20 provides that the Scheme may also apply to other persons as specified in that section. Section 20A extends the limitation of liability of persons to whom the scheme applies by virtue of sections 18 to 20.

² Professional Standards Act 2003 (Vic); Professional Standards Act 2004 (Qld); Professional Standards Act 2004 (SA); Professional Standards Act 1997 (WA); Professional Standards Act 2005 (Tas); Professional Standards Act 2004 (NT); Civil Law (Wrongs) Act 2002 (ACT)

she would suffer financial hardship in obtaining professional indemnity insurance to the levels set out in clause 3 below.

- 2.3 All participating members referred to in this clause 2 of the Scheme are subject to disciplinary measures under the Constitution and By-Laws of CPA Australia and are also subject to the professional indemnity insurance requirements under the By-Laws of CPA Australia.

3. Limitation of Liability

- 3.1 This Scheme only affects the Occupational Liability of a participant for damages³ arising from a Cause of Action to the extent to which the liability results in damages exceeding \$2 million.
- 3.2 Where a participant against whom a proceeding is brought relating to Occupational Liability in connection with Category 1 services is able to satisfy the court that the participant has the benefit of an Insurance Policy insuring the participant against the Occupational Liability and the amount payable under the Insurance Policy in respect of the Occupational Liability relating to the Cause of Action (including any amount payable by the person by way of excess under or in relation to the Policy) is not less than the Category 1 monetary ceiling determined in accordance with the table in clause 3.3, then the participant is not liable in damages in relation to that Cause of Action above the Category 1 monetary ceiling specified in clause 3.3.
- 3.3 The Category 1 monetary ceiling is an amount specified in the table below:

Groups	Monetary ceiling
1. Participants who at the Relevant Time were in an Accounting Practice which generated total annual fee income, for the financial year immediately preceding the Relevant Time, of less than \$10 million.	\$2 million
2. Participants other than those in Groups 1 and 3.	\$10 million
3. Participants who at the Relevant Time were in an Accounting Practice which generated total annual fee income, for the financial year immediately preceding the Relevant Time, greater than \$20 million.	\$75 million

³ Damages as defined in section 4 of the Act means:

- (a) damages awarded in respect of a claim or counter-claim or by way of set-off; and
- (b) costs in or in relation to the proceedings ordered to be paid in connection with such an award (other than costs incurred in enforcing a judgment or incurred on an appeal made by a defendant); and
- (c) any interest payable on the amount of those damages or costs.

- 3.4 Where a participant against whom a proceeding is brought relating to Occupational Liability in connection with Category 2 services is able to satisfy the court that the participant has the benefit of an Insurance Policy insuring the participant against the Occupational Liability, and the amount payable under the insurance policy in respect of the Occupational Liability relating to that Cause of Action (including any amount payable by the person by way of excess under or in relation to the policy) is not less than the Category 2 monetary ceiling determined in accordance with the table in clause 3.5 below, then the participant is not liable in damages in relation to that Cause of Action above the Category 2 monetary ceiling specified in clause 3.5.
- 3.5 The Category 2 monetary ceiling is the amount specified in the table below.

Groups	Monetary ceiling
1. Participants who at the Relevant Time were in an Accounting Practice which generated total annual fee income, for the financial year immediately preceding the Relevant Time, of less than \$10 million.	\$2 million
2. Participants other than those in Groups 1 and 3.	\$10 million
3. Participants who at the Relevant Time were in an Accounting Practice which generated total annual fee income, for the financial year immediately preceding the Relevant Time, greater than \$20 million.	\$20 million

- 3.6 Where a participant against whom a proceeding is brought relating to Occupational Liability in connection with Category 3 services is able to satisfy the court that the participant has the benefit of an Insurance Policy insuring the participant against the Occupational Liability, and the amount payable under the Insurance Policy in respect of the Occupational Liability relating to that Cause of Action (including any amount payable by the person by way of excess under or in relation to the Policy) is not less than the amount of the Category 3 monetary ceiling determined in accordance with the table in clause 3.7 below, then the participant is not liable in damages in relation to that Cause of Action above the Category 3 monetary ceiling specified in clause 3.7.

3.7 The Category 3 monetary ceiling is the amount specified in the table below.

Groups	Monetary ceiling
1. Participants who at the Relevant Time were in an Accounting Practice which generated total annual fee income, for the financial year immediately preceding the Relevant Time, of less than \$10 million.	\$2 million
2. Participants other than those in Groups 1 and 3.	\$10 million
3. Participants who at the Relevant Time were in an Accounting Practice which generated total annual fee income, for the financial year immediately preceding the Relevant Time, greater than \$20 million.	\$20 million

3.8. Pursuant to section 24 of the Act, this Scheme confers on CPA Australia a discretionary authority to specify, on application by a participant member, a higher maximum amount of liability not exceeding \$75 million than would otherwise apply under the Scheme in respect of any specified case or class of case of Category 2 services or Category 3 services.

3.9. In circumstances where the services provided by a participant comprise a combination of Category 1 services and any of:

- (a) Category 2 services;
- (b) Category 3 services;
- (c) Category 2 services and Category 3 services,

the participant's liability under this Scheme for damages in respect of a proceeding in relation to Occupational Liability in excess of the applicable amount specified in clause 3.1 will be determined in accordance with those provisions of the Scheme relating to Category 1 services only.

3.10. In circumstances where the services provided by a participant comprise a combination of Category 2 services and Category 3 services, the participant's liability under this Scheme for damages in respect of a proceeding in relation to Occupational Liability in excess of the applicable amount specified in clause 3.1 will be determined (subject to clause 3.9) in accordance with those provisions of the Scheme relating to Category 2 services only.

- 3.11. Nothing in this scheme is intended to increase, or has the effect of increasing, a participant's liability for damages to a person beyond the amount that, other than for the existence of this Scheme, the participant would be liable in law.
- 3.12. This Scheme only limits the amount of damages for which a participant is liable if and to the extent that it exceeds the amount specified in clause 3.1. Where the amount of damages in relation to a Cause of Action exceeds the amount specified in clause 3.1 liability for those damages will instead be limited to the amount specified in the applicable other provision of this clause 3.
- 3.13. Notwithstanding anything to the contrary contained in this scheme, if in particular circumstances giving rise to Occupational Liability, the liability of any participant should be capped both by this scheme and also by any other scheme under Professional Standards legislation (whether of this jurisdiction or under the law of any other Australian state or territory) and, if the amount of such caps should differ, then the cap which is higher shall be the applicable cap.

4. Definitions

- 4.1. In this Scheme, the following words and phrases have the following meanings:

"Accounting Practice" means the activities of a member including those who provide Public Accounting Services through an Approved Practice Entity (in accordance with the requirements of By-Law 9.3 of the By-Laws).

"Act" means *Professional Standards Act 1994 (NSW)*

"Acts" means state and territory legislation other than the Act, including:

- (a) *Professional Standards Act 2003 (Vic)*;
- (b) *Professional Standards Act 2004 (Qld)*;
- (c) *Professional Standards Act 2004 (SA)*;
- (d) *Professional Standards Act 1997 (WA)*;
- (e) *Professional Standards Act 2005 (Tas)*;
- (f) *Professional Standards Act 2004 (NT)*; and
- (g) *Civil Law (Wrongs) Act 2002 (ACT)*

"Approved Practice Entity" means such entities as defined as Approved Practice Entity in By-Law 9.3 of the By-Laws.

“By – Laws” means the By-Laws of CPA Australia Limited.

"Category 1 services" means:

- (a) all services required by Australian law to be provided only by a registered company auditor;
- (b) all other services provided by a registered company auditor in his or her capacity as auditor;
- (c) all services the deliverables from which:
 - (i) will be used in determining the nature, timing and extent of audit procedures in the context of an audit of a financial report; or
 - (ii) will be incorporated into the financial report of an entity; or
 - (iii) are required by law or regulation to be filed with a regulator (excluding returns signed by a registered tax agent).

"Category 2 services" means:

- (a) services to which Chapter 5 or Chapter 5A of the *Corporations Act* 2001 (Cth) applies;
- (b) services provided pursuant to section 233(2) of the *Corporations Act*;
- (c) services to which the *Bankruptcy Act* 1966 (Cth) applies; or
- (d) services arising out of any court appointed liquidation or receivership.

"Category 3 services" means any services provided by a participant in the performance of his, her or its occupation, which are not Category 1 or Category 2 services.

“Cause of Action” means and includes all causes of action arising from the same source or originating cause.

“Financial Services” means financial services as described in Chapter 7 of the *Corporations Act* 2001 (Cth) and the Regulations made under it, as amended from time to time but does not include those provided under a Limited Licence.

"Insurance Policy" means an insurance policy that complies with By-Law 9.8 of the By-Laws and section 27 of the Act.

"Limited Licence" means a licence to provide only limited financial services as defined in Regulations 7.8.12A and 7.8.14B of the Corporations Regulations 2001 (Cth).

"Occupational Liability" has the same meaning as is ascribed to that term in the Act⁴ and Acts.

"Public Accounting Services" means those services defined as public accounting services in the By-Laws.

"Principal(s)" for the purposes of clauses 3.3, 3.5, and 3.7 means a person(s) in a Public Accounting Practice who is affiliated with the Controlled Person within the meaning of By-Law 1.2(c) of the By-Laws.

"Public Practice Certificate" means a Public Practice Certificate issued by CPA Australia Ltd, permitting a Member to provide Public Accounting Services.

"Relevant Time" means, in respect of a liability potentially limited by the Scheme, the period from the time(s) of the act(s) or omission(s) giving rise to the liability until the date that is seven years after the last such act or omission took place.

5. Jurisdiction

- 5.1. This Scheme is intended to operate in New South Wales. This Scheme is also intended to operate in the Australian Capital Territory, the Northern Territory of Australia, Victoria, Queensland, South Australia, Tasmania and Western Australia by way of mutual recognition under the professional standards legislation.

6. Commencement date and duration

- 6.1.1. This Scheme will commence on the day after the date of Gazettal in each of the following jurisdictions respectively: New South Wales, the Australian Capital Territory, the Northern Territory of Australia, Queensland, South Australia and Western Australia; and
- 6.1.2. In the event the Scheme or a notice relating to the Scheme is published in the Gazette in each of Victoria and Tasmania, on such day that is two (2) months after the date of its publication in each of those jurisdictions respectively.

⁴ Occupational liability is defined in the Act as meaning "civil liability arising (in tort, contract or otherwise) directly or vicariously from anything done or omitted by a member of an occupational association acting in the performance of his or her occupation".

- 6.2. The Scheme will operate for and is intended to remain in force for a period of two (2) years from the date of commencement in each jurisdiction for which it is in force unless it is revoked, extended or ceases in accordance with section 32 of the Act.

PROFESSIONAL STANDARDS ACT 1994

Notification Pursuant to Section 13

Pursuant to section 13 of the *Professional Standards Act 1994*, I authorise the publication of the Instrument amending the Law Society of South Australia Professional Standards Scheme. The amendment will commence two months after the publication of the Instrument in the NSW Government Gazette.

MATT KEAN, MP
Minister for Innovation and Better Regulation

**INSTRUMENT AMENDING THE LAW SOCIETY OF SOUTH AUSTRALIA
PROFESSIONAL STANDARDS SCHEME**
Professional Standards Act 2004 (SA)

PREAMBLE

- A. The Law Society of South Australia (“the Society”) is an occupational association
- B. The Law Society of South Australia Professional Standards Scheme (“the Scheme”) commenced on 1 July 2017.
- C. This instrument of amendment is prepared by the Society for the purposes of amending the Scheme to allow for mutual recognition of the Scheme in Tasmania.

AMENDMENT TO THE SCHEME

- 1. This instrument to amend the Law Society of South Australia Professional Standards Scheme is prepared pursuant to section 18 of the *Professional Standards Act 2004 (SA)* by the Law Society of South Australia, whose business address is Level 10, Terrace Towers, 178 North Terrace, Adelaide, SA, 5000.

Operation of the Scheme in multiple jurisdictions

- 1.1 Amend recital G of the Preamble to delete the phrase “except Tasmania.”
- 1.2 Amend clause 3.2 in the Scheme to insert the word “Tasmania,” between the words “Western Australia,” and “the ACT” thus:

The Scheme applies in New South Wales, Victoria, Queensland, Western Australia, Tasmania, the ACT and the Northern Territory pursuant to the corresponding laws of each of those jurisdictions respectively.

Definitions

- 1.3 In clause 1 in the Scheme, delete the following references to the discretionary authority to specify a higher amount of liability from the definition “Monetary Ceiling”, thus:
 - 1.3.1 Delete the phrase “(a) the higher of”; and
 - 1.3.2 Delete the paragraph “OR (b) such higher amount as has been specified in relation to a specified Scheme Participant in respect of such case or class of case or generally as has been specified by the Society pursuant to clause 5.1;”.

Conferral of discretionary authority

- 1.4 Amend clause 5.1 in the Scheme to delete the words “Monetary Ceiling” from the final phrase of the paragraph and replace with the word “amount”, thus:

The Scheme confers on the Society a discretionary authority, on application by a Scheme Participant, to specify in relation to the person a higher maximum amount of liability than would otherwise apply under the Scheme in relation to the person either in all cases or

in any specified case or class of case, being a specified amount not exceeding \$50 million.

Limitation of liability

- 1.5 Amend clause 6.4 in the Scheme to insert the phrase “and the Acts” between the words “Scheme” and “applies” in the first line of the paragraph, thus:

The limitation of liability that, in accordance with this Scheme and the Acts, applies in respect of an act or omission continues to apply to every cause of action founded on it, irrespective of when the proceedings are brought in respect of it, and even if the Scheme has been amended or has ceased to be in force.

- 1.6 Amend clause 6.5 in the Scheme to insert the phrase “and corresponding provisions” between the words “the Act” and “the Scheme” in the first line of the paragraph, thus:

For the purposes of section 28 of the Act and corresponding provisions, the Scheme only affects a liability for damages arising from a Single Claim (including a claim by a person who has 2 or more causes of action arising out of a single event) exceeding \$1,500,000.

Duration of the Scheme

- 1.7 Amend clause 7.1 in the Scheme to insert the following text after the date “1 July 2017”:

except in relation to its application to Tasmania in which case the Scheme will commence on the date which is 2 months after the date of its publication in the Government Gazette of Tasmania.

COMMENCEMENT

- 2 The amendments to the Scheme made by this instrument will commence 2 months after the date of its publication in the Gazette.

Professional Standards Act 2004 (SA)

THE LAW SOCIETY OF SOUTH AUSTRALIA PROFESSIONAL STANDARDS SCHEME

Preamble

- A. The Law Society of South Australia (**the Society**) is an occupational association.
- B. The Society has made an application to the Professional Standards Council, appointed under the *Professional Standards Act 2004 (SA)* (**the Act**), for a Scheme under the Act.
- C. The Scheme is prepared by the Society for the purposes of limiting occupational liability to the extent to which such liability may be limited under the Act.
- D. The Scheme propounded by the Society is to apply to Admitted Members or Company Members of the Society who have professional indemnity insurance that complies with the *Legal Practitioners Act 1981 (SA)* in respect of a liability potentially limited by the Scheme.
- E. The Society has furnished the Council with a detailed list of the risk management strategies intended to be implemented in respect of its members and the means by which those strategies are intended to be implemented.
- F. The Scheme is intended to commence on 1 July 2017 and remain in force for five (5) years from its commencement unless, prior to that time, it is revoked, its operation ceases, or it is extended pursuant to section 34 of the Act.
- G. The Scheme is also intended to apply in all other jurisdictions.

1 Definitions

“Act” means the *Professional Standards Act 2004 (SA)*;

“Acts” means the Act and each corresponding law;

“Admitted Member” means a person who is or was at a relevant time an Admitted Member within the meaning of and pursuant to the Rules of the Society;

“Company Member” means a company who is or was at a relevant time a Company Member within the meaning of and pursuant to the Rules of the Society;

“corresponding law” means a law of another jurisdiction that corresponds to the Act;

“Court” has the same meaning as it has in the Acts;

“Duration of the Scheme” means the period commencing on the date specified in clause 7.1 and ending upon the cessation of the Scheme pursuant to clause 7.2;

“Exempted Member” means an Admitted Member or Company Member who is or was at a Relevant Time exempted by the Society from participation in the Scheme pursuant to clause 4.3;

“*Law Practice*” means (in accordance with the *Legal Practitioners Act*):

- (a) a legal practitioner who is a sole practitioner; or
- (b) a firm of legal practitioners; or
- (c) an incorporated legal practice; or
- (d) a Community Legal Centre;

“*Legal Practitioners Act*” means the *Legal Practitioners Act 1981 (SA)* or any Act enacted in substitution thereof;

“*Monetary Ceiling*” means, in respect of a liability in respect of a cause of action founded on an act or omission occurring after the commencement of the Scheme:

Description	Monetary ceiling
Participating Admitted Members or Company Members other than those in item 2 below.	\$1.5 million
Participating Admitted Members or Company Members who were as at the 30 June immediately preceding the Relevant Time in a Law Practice: consisting of greater than 20 Admitted Members; or which generated total annual fee income for the financial year ended on 30 June immediately preceding the Relevant Time greater than \$10 million.	\$10 million

“*occupational liability*” has the same meaning as it has in the Acts;

“*person*” means an individual or a body corporate;

“*relevant time*” means, in respect of a liability potentially limited by the Scheme, the time(s) of the act(s) or omission(s) giving rise to the liability;

“*the Scheme*” means the Law Society of South Australia Scheme constituted herein;

“*Scheme Participant*” means a person referred to in clause 4.1 or 4.2;

“*the Society*” means the Law Society of South Australia.

2 Occupational Association

2.1 The Scheme is a Scheme under the Act prepared by the Society whose business address is Level 10, 178 North Terrace Adelaide South Australia.

3 Jurisdictions in which the Scheme Applies

3.1 The Scheme applies in South Australia pursuant to the Act.

3.2 The Scheme applies in New South Wales, Victoria, Queensland, Western Australia, Tasmania, the ACT and the Northern Territory pursuant to the corresponding laws of each of those jurisdictions respectively.

3.3 Notwithstanding anything to the contrary contained in this Scheme, if in particular

circumstances giving rise to occupational liability, the liability of any person who is subject to this Scheme should be capped by both this Scheme and also by any other Scheme under Professional Standards legislation (whether of this jurisdiction or under the law of any other Australian state or territory) and if the amount of such caps should differ, then the cap on the liability of such person arising from such circumstances which is higher shall be the applicable cap.

4. Persons to Whom the Scheme Applies

- 4.1 The Scheme applies to all persons who:
 - 4.1.1 are or at the relevant time were Admitted Members or Company Members of the Society;
 - 4.1.2 are or were at the relevant time not Exempted Members; and
 - 4.1.3 have professional indemnity insurance that complies with the *Legal Practitioners Act* in respect of a liability potentially limited by the Scheme.
- 4.2 The Scheme applies to all persons to whom the Scheme applies by virtue of sections 20, 21, and 22 of the SA Act and the corresponding sections of the corresponding laws.
- 4.3 The Society may, upon application by an Admitted or Company Member, exempt that person from participation in the Scheme with effect from a date specified by the Society on or after the date on which the exemption is granted.
- 4.4 The Society may, upon application by an Admitted or Company Member, revoke an exemption of that person from participation in the Scheme with effect from a date specified by the Society.

5. Conferral of discretionary authority

- 5.1 The Scheme confers on the Society a discretionary authority, on application by a Scheme Participant, to specify in relation to the person a higher maximum amount of liability than would otherwise apply under the Scheme in relation to the person either in all cases or in any specified case or class of case, being a specified amount not exceeding \$50 million.

6. Limitation of Liability

- 6.1 The occupational liability of a person who is or at the relevant time was a Scheme Participant in respect of a cause of action founded on an act or omission occurring during the Duration of the Scheme is limited to the amount of the Monetary Ceiling.
- 6.2 The liability which is limited by clause 6.1 extends to a liability for damages (including interest and costs) within the meaning of the Acts but excludes a liability to which the Act does not apply from time to time by reason of section 5 thereof or, if the liability is governed by a corresponding law, excludes a liability to which the corresponding law does not apply from time to time by reason of its provisions.
- 6.3 The operation of clause 6.1 limiting the liability of a person is subject to the

proviso that the person is able to satisfy the Court that:

- 6.3.1 the person has the benefit of an insurance policy complying with the *Legal Practitioners Act* insuring the person against the occupational liability to which the cause of action relates; and
- 6.3.2 the amount payable under the policy in respect of that occupational liability is not less than the amount of the Monetary Ceiling.
- 6.4 The limitation of liability that, in accordance with this Scheme and the Acts, applies in respect of an act or omission continues to apply to every cause of action founded on it, irrespective of when the proceedings are brought in respect of it, and even if the Scheme has been amended or has ceased to be in force.
- 6.5 For the purposes of section 28 of the Act and corresponding provisions, the Scheme only affects a liability for damages arising from a Single Claim (including a claim by a person who has 2 or more causes of action arising out of a single event) exceeding \$1,500,000.

7. Duration of the Scheme

- 7.1 The Scheme commences on 1 July 2017 except in relation to its application to Tasmania in which case the Scheme will commence on the date which is 2 months after the date of its publication in the Government Gazette of Tasmania.
- 7.2 Subject to clause 7.3, the Scheme will remain in force for a period of 5 years from its commencement unless:
 - 7.2.1 it is revoked or ceases in accordance with the Act, or
 - 7.2.2 it is extended in accordance the Act.
- 7.3 The Scheme will cease to operate in a jurisdiction referred to in clause 3.2 if it is revoked or ceases in accordance with the corresponding law of that jurisdiction.

COUNCIL NOTICES

ALBURY CITY COUNCIL

Roads Act 1993, Section 16

Dedication of Land as Public Road

Notice is hereby given pursuant to section 16 of the *Roads Act 1993*, that the land described in the schedule below is dedicated to the public as public road.

FRANK ZAKNICH, General Manager, Albury City Council, PO Box 323, Albury NSW 2640.

Schedule

Lot 1 in DP1236200, being the laneway joining Thurgoona Street and Small Street, roughly parallel to and between Forest Hill Avenue and Pemberton Street, as well as that part of Small Street between the abovementioned laneway and Pemberton Street, in Albury.

[9455]

COFFS HARBOUR CITY COUNCIL

ROADS ACT 1993

Naming of Roads

Notice is hereby given that Coffs Harbour City Council, pursuant to section 162 of the *Roads Act 1993*, has officially named the road(s) as shown hereunder:

Name	Locality
MCLAUGHLIN ROAD	Corindi Beach
Description	
Off Pacific Highway	

Name	Locality
SIMMONS FLAT ROAD	Corindi Beach
Description	
New road off McLaughlin Road and Pacific Highway, Corindi Beach	

STEPHEN MCGRATH, General Manager, Coffs Harbour City Council, Locked Bag 155, COFFS HARBOUR NSW 2450

GNB Ref: 0240

[9456]

COFFS HARBOUR CITY COUNCIL

ROADS ACT 1993

Naming of Roads

Notice is hereby given that Coffs Harbour City Council, pursuant to section 162 of the *Roads Act 1993*, has officially named the road(s) as shown hereunder:

Name	Locality
MERMAID DRIVE	Sandy Beach
Description	
Coming off Somervale Road in a easterly direction before heading south where it meets Oceanic Drive.	

Name	Locality
ROCKPOOL AVENUE	Sandy Beach
Description	
Coming off Mermaid Drive in a southerly direction where it joins Somervale Road, adjacent to Sandcastle Drive.	

Name	Locality
SANDCASTLE DRIVE	Sandy Beach
Description	
Coming of Mermaid Drive in a southerly direction where it joins Somervale Road.	

Name	Locality
SHOREBIRD WAY	Sandy Beach
Description	
Coming off Somervale Road in a southerly direction before heading east where it joins Mermaid Drive.	

STEPHEN MCGRATH, General Manager, Coffs Harbour City Council, Locked Bag 155, COFFS HARBOUR NSW 2450

GNB Ref: 0237

[9457]

COFFS HARBOUR CITY COUNCIL

ROADS ACT 1993

Naming of Roads

Notice is hereby given that Coffs Harbour City Council, pursuant to section 162 of the *Roads Act 1993*, has officially named the road(s) as shown hereunder:

Name	Locality
SOLITARY ISLANDS WAY	Ararawarra, Corindi Beach, Woolgoolga
Description	
Extension of the existing Solitary Islands Way. Rename Eggins Drive, from Ararawarra interchange off Pacific Highway to Tasman Street as an extension of Solitary Islands Way. Rename former Pacific Highway from Tasman Street to highway interchange at Range Road as an extension of Solitary Islands Way.	

STEPHEN MCGRATH, General Manager, Coffs Harbour City Council, Locked Bag 155, COFFS HARBOUR NSW 2450

GNB Ref: 0239

[9458]

COFFS HARBOUR CITY COUNCIL

ROADS ACT 1993

Naming of Roads

Notice is hereby given that Coffs Harbour City Council, pursuant to section 162 of the *Roads Act 1993*, has officially named the road(s) as shown hereunder:

Name	Locality
BURLEIGH CRESCENT	Woolgoolga
Description	
Off Solitary Islands Way	

STEPHEN MCGRATH, General Manager, Coffs Harbour City Council, Locked Bag 155, COFFS HARBOUR NSW 2450

GNB Ref: 0238

[9459]

COFFS HARBOUR CITY COUNCIL

ROADS ACT 1993

Naming of Roads

Notice is hereby given that Coffs Harbour City Council, pursuant to section 162 of the *Roads Act 1993*, has officially named the road(s) as shown hereunder:

Name	Locality
MOONLIGHT CRESCENT	Coffs Harbour
Description	
Road extending off Parkland Parade, Coffs Harbour.	

Name	Locality
PLATINUM PLACE	Coffs Harbour
Description	
Road extending off Ted Ovens Drive, Coffs Harbour.	

STEPHEN MCGRATH, General Manager, Coffs Harbour City Council, Locked Bag 155, COFFS HARBOUR NSW 2450

GNB Ref: 0242

[9460]

EUROBODALLA SHIRE COUNCIL

Roads Act 1993, Section 10

Dedication of Land as Public Road

(Ref No. 98.2538.E)

NOTICE is hereby given that pursuant to Section 10 of the *Roads Act 1993*, Eurobodalla Shire Council hereby dedicates the land described in the Schedule below as public road.

Schedule

Lot 1 Deposited Plan 882626 Parish of Moruya County of Dampier

Lot 2 Deposited Plan 882626 Parish of Moruya County of Dampier

Dr Catherine Dale
General Manager
Eurobodalla Shire Council
PO Box 99, Moruya NSW 2537

[9461]

SINGLETON COUNCIL

ROADS ACT 1993, Section 10

Local Government Act 1993 Section 47f(2)(A)

Dedication of Land as Public Road for the Purposes of Road Widening

NOTICE is hereby given by Singleton Council, in pursuant to Section 10 of the *Roads Act 1993*, and Section 47f(2)(a) of the *Local Government Act 1993* that it dedicates the land described in the Schedule below as public road for the purposes of road widening. JASON LINNANE, General Manager, Singleton Council, PO Box 314, SINGLETON, NSW 2330.

SCHEDULE

The following piece or parcel of land known as:

- Lot 201 DP 1025392 in the Council of Singleton, Parish of Belford, County of Northumberland;
- Lot 5 DP823737 in the Council of Singleton, Parish of Belford, Ovingham and Rothbury, County of Northumberland;
- Lot 42 DP 852833 in the Council of Singleton, Parish of Ovingham, County of Northumberland;
- Lot 3 DP 249228 in the Council of Singleton, Parish of Ovingham, County of Northumberland;
- Lot 4 DP 249228 in the Council of Singleton, Parish of Ovingham, County of Northumberland;
- Lot 5 DP249228 in the Council of Singleton, Parish of Ovingham, County of Northumberland;
- Lot 61 DP856636 in the Council of Singleton, Parish of Ovingham, County of Northumberland;
- Lot 5 DP251325 in the Council of Singleton, Parish of Rothbury, County of Northumberland;

- Lot 50 DP 1067143 in the Council of Singleton, Parish of Rothbury, County of Northumberland;
- Lot 2 DP 844544 in the Council of Singleton, Parish of Rothbury, County of Northumberland;
- Lot 1 DP 844544 in the Council of Singleton, Parish of Rothbury, County of Northumberland;
- Lot 121 DP 1069307 in the Council of Singleton, Parish of Rothbury, County of Northumberland

[9462]

SINGLETON SHIRE COUNCIL

ROADS ACT 1993

Naming of Roads

Notice is hereby given that Singleton Shire Council, pursuant to section 162 of the *Roads Act 1993*, has officially named the road(s) as shown hereunder:

Name	Locality
BUNJIM VALLEY DRIVE	Putty
Description	
Extend the length of Bunjim Valley Drive from approximately 2km to 5km. Bunjim Valley Drive to originate 5km from the origin of Yengo Drive and terminate near the access point of Lot 12 DP 1037851 (property address: 878E Yengo Drive, Putty NSW 2330).	

HELLEN CROSS, GIS Officer, Singleton Shire Council, 12-14 Queen Street, SINGLETON NSW 2330

GNB Ref: 0245

[9463]

SINGLETON SHIRE COUNCIL

ROADS ACT 1993

Naming of Roads

Notice is hereby given that Singleton Shire Council, pursuant to section 162 of the *Roads Act 1993*, has officially named the road(s) as shown hereunder:

Name	Locality
YENGO DRIVE	Putty
Description	
Reduce the Length of Yengo Drive from 15km to 12km.	

HELLEN CROSS, GIS Officer, Singleton Shire Council, 12-14 Queen Street, SINGLETON NSW 2330

GNB Ref: 0244

[9464]

SINGLETON SHIRE COUNCIL

ROADS ACT 1993

Naming of Roads

Notice is hereby given that Singleton Shire Council, pursuant to section 162 of the *Roads Act 1993*, has officially named the road(s) as shown hereunder:

Name	Locality
BIMBADEEN ROAD	Stanhope
Description	
Extend the current name of Bimbadeen Road from approximately 5.3km to 8.9.	

Name	Locality
FIGTREE RISE	Stanhope
Description	
Approximately 7.6km from the originate of Cranky Corner Road (south) and continue for 1.9km in a southerly direction to end at Lot 36 DP1163919	

Name	Locality
FOREST GLADE	Stanhope
Description	
5.3km from the originate of Cranky Corner South and extend 1.5km in a northerly direction, finishing at lots 22 and 23 DP1053250	

HELLEN CROSS, GIS Officer, Singleton Shire Council, 12-14 Queen Street, SINGLETON NSW 2330

GNB Ref 0243

[9465]

SINGLETON SHIRE COUNCIL

ROADS ACT 1993

Naming of Roads

Notice is hereby given that Singleton Shire Council, pursuant to section 162 of the *Roads Act 1993*, has officially named the road(s) as shown hereunder:

Name	Locality
RESERVE ROAD	Putty
Description	
Road originates off Putty Valley Road in PUTTY NSW. It extends in a northerly direction for approximately 930m to the boundary of Lot 6 DP 1180923, at which point it extends in an easterly direction for approximately 750m to the boundary of Lot 4 DP 1180923	

Name	Locality
TURNBULL CREEK ROAD	Putty
Description	
Road originates off unnamed road in PUTTY NSW, adjacent to the north eastern corner of Lot 2 DP 753782. It extends in a westerly direction for approximately 650m, at which point it extends in a north westerly direction for approximately 1.25km to the boundary of Lot 2 DP 1184341.	

HELLEN CROSS, GIS Officer, Singleton Shire Council, 12-14 Queen Street, SINGLETON NSW 2330

GNB Ref: 0246

[9466]

THE HILLS SHIRE COUNCIL

ROADS ACT 1993

Naming of Roads

Notice is hereby given that The Hills Shire Council, pursuant to section 162 of the *Roads Act 1993*, has officially named the road(s) as shown hereunder:

Name	Locality
INDALIA CLOSE	Kellyville
Description	
Blind road ending in a cul-de-sac and extending from Tallaganda Street near Wattleridge Crescent (existing). This road was previously approved for use with the type "Street" however the change to "Close" reflects the fact it now ends in a cul-de-sac head.	

MICHAEL EDGAR, General Manager, The Hills Shire Council, 3 Columbia Court, BAULKHAM HILLS NSW 2153

GNB Ref: 0241

[9467]

WILLOUGHBY CITY COUNCIL

NOTICE

Local Government Act 1993, Section 50

NOTICE is hereby given that the land described in the schedule below is vested in Willoughby City Council pursuant to the provisions of Section 50 of the *Local Government Act 1993* and is dedicated as a public reserve.

Debra Just
General Manager
Willoughby City Council

SCHEDULE

Lot 230 in Deposited Plan 12497 at Castlecrag in the Local Government Area of Willoughby, Parish of Willoughby and County of Cumberland and being the land comprised in Certificate of Title Folio Identifier 230/12497.

[9468]

PRIVATE NOTICES

Company Notices

CORPORATIONS ACT 2001

FORM 529

Subregulation 5.6.12(2)

Notice of Final Meeting (Members)

The Scot's School Albury Parents & Friends Association Inc (In Liquidation)

Notice is given that a Final Meeting of the Members of The Scot's School Albury Parents & Friends Association Inc (In Liquidation) will be held at the offices of Suite 103, 1st Floor, Wollundry Chambers, Johnston Street, Wagga Wagga, NSW 2650 on the 24th January 2018 at 11:00 AM.

The purpose of the meeting is to lay accounts before it, showing the manner in which the winding up has been conducted and the property of the Company disposed of, and for hearing any explanation that may be given by the Liquidator.

Dated this 15th December 2017.

Steven Priest – Liquidator.
Chamberlain's SBR
Chartered Accountants,
PO Box 852
Wagga Wagga NSW 2650

[9469]